

2010

OPERATOR'S GUIDE

75/90

PL / PX / SL / WEL / WEX / WDEL / WDEX

215926 EN

FEATURES AT A GLANCE

Easy to Own and Operate

- Three-Year Limited Warranty
- No Scheduled Dealer Maintenance for Three Years of Normal Recreational Use
- No Operational Break-In Procedure
- Easy Starts (no choking or priming)
- Digital Engine Management
- Self Flushing Cooling System
- Long Term Storage Design
- Simplified Winterization Procedure
- Digital Diagnostics
- Low Oil Usage
- CANbus Capable

Durable and Reliable

- Full Corrosion Protection
- *Evinrude E-TEC* Lubrication System
- Auto-Calibrated Linkage
- Robust, Heavy-Duty Design
- Posi-Lock Latches
- Extra Capacity Water Pump
- Iridium Spark Plugs
- Vibration Isolated Electronics
- Beltless 25 Amp Charging System
- Stainless Steel Thermostats
- Nickel/Chrome-Faced Piston Rings
- Micro Finished Connecting Rods/Crankshaft

Cleaner and Quieter

- EPA Emissions Compliance
- European Union Emissions Compliance
- California 3-Star Emissions Compliance
- Sealed Fuel System
- Low Friction Design (No powerhead gears, belts, cams, oil scraping rings, or mechanical oil pump)
- Full Length Insulated Lower Pans
- Quiet Signature Sound
- Air Intake/Silencer
- Idle Air Bypass

The following trademarks are the property of Bombardier Recreational Products Inc. or its affiliates:

Evinrude®

Evinrude® *E-TEC*®

Evinrude®/*Johnson*® *Genuine Parts*

Evinrude®/*Johnson*® *XD100*™

Evinrude®/*Johnson*® *XD50*™

Evinrude®/*Johnson*® *XD30*™

BRP Logo

2+4™ *Fuel Conditioner*

HPF XR™ *Gearcase Lubricant*

HPF Pro™ *Gearcase Lubricant*

I-Command™

S.A.F.E.™

SystemCheck™

Triple-Guard™ *Grease*



Dear Boating Enthusiast,

Congratulations on your purchase of our industry-leading *Evinrude E-TEC* outboard! Your purchase comes with the full commitment and backing of the BRP Outboard Engine team. We know your *Evinrude E-TEC* outboard will provide you with years of reliable use, and we hope you will enjoy using it as much as we enjoyed designing and building this innovative product.

You can be proud you purchased an *Evinrude E-TEC* outboard with the following benefits.

EASY TO OWN & OPERATE

With your *Evinrude E-TEC* outboard there is no more time wasted in the shop. In fact, you only have to bring your *Evinrude E-TEC* outboard in for dealer scheduled maintenance every 300 hours or every three years of normal recreational use. That's three trips to the shop in nine years... four trips in twelve years... five trips in fifteen years... you get the picture! And if that is not enough, with your new outboard you will have zero oil changes, absolutely no break-in period, and a simple winterization process that can be done at the boat ramp or in your driveway. We are proud of how easy we have made it for you to own this outboard. Hopefully it means you will be spending more time on the water each year.

POWER & PERFORMANCE

Evinrude E-TEC outboards have been engineered to outperform anything on the water—acceleration, top-end speed, any size, any horsepower, across the line. And for your buddies who own a four-stroke? Well, they cannot touch our power-to-weight ratio. And you can tell them that no four-stroke comes close to the pure power and torque of an *Evinrude E-TEC* outboard.

DURABILITY / QUALITY / RELIABILITY

Fewer parts. Fewer problems. Every *Evinrude E-TEC* outboard component is tested and retested for maximum performance and longer life. Parts are bigger and stronger to work harder and last longer.

CLEAN & QUIET

You do not even have to think about emissions—anywhere in the country; anywhere in the world. *Evinrude E-TEC* outboards are the only outboard marine engines to have received a Clean Air Excellence Award from the United States Environmental Protection Agency (EPA). The entire *Evinrude E-TEC* line meets or exceeds all worldwide emission standards. We have even got 3-Star certification from the toughest of the tough: the California Air Resources Board. And thanks to the sophisticated, acoustically tuned air intake and exhaust systems, you will not be filling the air with a lot of noise either.

BRP is proud you have purchased this technology-leading *Evinrude E-TEC* outboard engine. We thank you for your business and wish you many years of enjoyable use.

Happy Boating,

A handwritten signature in black ink, appearing to read "Roch Lambert". The signature is fluid and cursive, with a large loop at the beginning and a long tail extending to the right.

Roch Lambert

Vice President, General Manager
Outboard Engines

TABLE OF CONTENTS

ABOUT THIS GUIDE	6
IMPORTANT SAFETY MESSAGES	7
PRODUCT REFERENCES, ILLUSTRATIONS AND SPECIFICATIONS	9

USING YOUR EVINRUDE E-TEC OUTBOARD

USING YOUR E-TEC OUTBOARD

SAFETY INFORMATION ON THE OUTBOARD	12
WARNING SYMBOLS	12
HANG TAG	12
REMOTE CONTROL DECALS	13

COMPONENT IDENTIFICATION

OIL AND FUEL	16
OIL REQUIREMENTS	16
OILING SYSTEM	16
FUEL REQUIREMENTS	17
FUEL ADDITIVES	18
FUEL SYSTEM OPERATION	18

OPERATION

SAFETY INFORMATION	19
ENGINE STARTING	19
EMERGENCY STARTING	22
REMOTE CONTROLS	23
SHIFTING AND SPEED CONTROL	25
FUEL ECONOMY	25
POWER TRIM AND TILT	26
TILTING AND TRIM ADJUSTMENT – MANUAL TILT	28
TRAILERING	31
IMPACT DAMAGE	32
EMERGENCY STARTING	33

SPECIAL OPERATING CONDITIONS

SALT WATER	35
WEEDY WATER	36
SHALLOW WATER	36
UNDER TOW	36
DUAL OUTBOARD OPERATION	36
FREEZING WEATHER	36
HIGH ALTITUDE	36

ENGINE MONITORING

GAUGES	37
SYSTEM SELF-TEST	37
ENGINE MONITOR WARNINGS	37
ENGINE OVERHEATING	39

ROUTINE INSPECTION CHECKLIST

MAINTENANCE

ENGINE EMISSIONS INFORMATION

MAINTENANCE SCHEDULE

SERVICE TIPS

FLUSHING	44
SUBMERGED OUTBOARD	44
OUTBOARD EXTERNAL FINISH	44
SCRATCH REPAIR	44

HULL FINISH	44
SPARK PLUGS	45
FUSE	45
TRANSPORTING / STORAGE	45
STORAGE	46
SHORT-TERM STORAGE	46
LONG-TERM STORAGE (WINTERIZATION)	46
PRE-SEASON CHECK	49
TROUBLESHOOTING	50

PRODUCT INFORMATION

RIGGING AND ACCESSORIES	52
PROPELLER	52
BATTERY	53
WATER PRESSURE	54
ADJUSTMENTS	55
SPECIFICATIONS	57
PRODUCT WARRANTY INFORMATION	58
BOMBARDIER RECREATIONAL PRODUCTS LIMITED WARRANTY FOR 2010 EVINRUDE OUTBOARD ENGINES SOLD IN THE UNITED STATES AND CANADA	58
CALIFORNIA EMISSION CONTROL WARRANTY STATEMENT	61
PRODUCT WARRANTY INFORMATION	63
BRP LIMITED WARRANTY FOR 2010 EVINRUDE OUTBOARD ENGINES USED IN EUROPEAN UNION MEMBER STATES, TURKEY, AUSTRALIA, NEW ZEALAND AND JAPAN	63
PRODUCT WARRANTY INFORMATION	66
BRP LIMITED WARRANTY FOR 2010 EVINRUDE OUTBOARD ENGINES USED IN AFRICA, MIDDLE EAST, LATIN AMERICA, PACIFIC ISLANDS, ASIA, ALBANIA, FORMER YUGOSLAVIAN REPUBLIC OF MACEDONIA, SERBIA AND MONTENEGRO, BOSNIA AND HERZEGOVINA AND THE COMMONWEALTH OF INDEPENDENT STATES	66
READINESS TEST	69
FREQUENTLY ASKED QUESTIONS	71
CHANGE OF ADDRESS / CHANGE OF OWNERSHIP	73
CONFIRMATION OF RECEIPT	75

ABOUT THIS GUIDE

This Operator's Guide is an essential part of your *Evinrude E-TEC* outboard. It contains pertinent information which, if followed, will provide you with a thorough understanding needed for proper operation, maintenance, care, and—above all—safety. Safety is our first priority and it should be yours too. It is strongly recommended you read this Guide from cover to cover. The more you know and understand about your *Evinrude E-TEC* outboard, the greater the safety and pleasure you will get from using it. Following this recommendation will assure the completeness of the information essential to your safety, the safety of any passengers, and other water users.

This Operator's Guide identifies important safety messages.

Although the mere reading of such information does not eliminate the hazard, the understanding and application of the information will promote the correct use of your outboard engine.



Warning Symbols in this Guide

How can you reduce the risk of death, personal injury, and possible property damage? This Operator's Guide answers such questions and are contained in boxes highlighted by the Safety Alert Symbol. It is imperative to read, understand, and follow these comments.

This Guide should be kept in a waterproof bag with the outboard at all times during operation. If the product ownership is transferred, this Guide should be forwarded to the new owners.

A responsible, educated boater will fully appreciate the pleasures of boating and will be a safe boater. Boating Safety Classes are conducted by the U.S. Coast Guard Auxiliary, the U.S. Power Squadron and some Red Cross Chapters. For information about classes, call toll free 1-800-336-BOAT.

For additional information about boating safety and regulations, call:

- U.S. Coast Guard Boating Safety Hotline
- 1-800-368-5647.

Outside North America please contact your Dealer or distributor for details about boating safety.

This Operator's Guide uses the following signal words identifying important safety messages.



DANGER

Indicates a hazardous situation which, if not avoided, will result in death or serious injury



WARNING

Indicates a hazardous situation which, if not avoided, could result in death or serious injury



CAUTION Indicates a hazardous situation which, if not avoided, could result in minor or moderate injury.



NOTICE Indicates an instruction which, if not followed, could severely damage engine components or other property.

IMPORTANT: Identifies information that will help with assembly and operation of the product.

Additionally, Bombardier Recreational Products (BRP) has identified key information that is essential to the operation of your *Evinrude E-TEC* outboard.



Key information appears throughout this Guide in gray boxes with a key above the text. This highlighted information is a vital reference when using your outboard.

IMPORTANT SAFETY MESSAGES

This Operator's Guide contains essential information to help prevent personal injury and damage to equipment. Safety messages appear throughout this Guide in the applicable section.

Be careful! Human error is caused by many factors: carelessness, fatigue, overload, preoccupation, unfamiliarity of operator with the product, drugs and alcohol to name a few. Damage to your boat and outboard can be fixed in a short period of time, but injury or death, has a lasting effect.

WARNING

For your safety and the safety of others, follow all safety warnings and recommendations. Do not disregard any of the safety precautions and instructions.

Anyone operating your boat should first read and understand this guide before they operate your boat and outboard.

SAFETY MEASURES — General

 To fully appreciate the pleasures, enjoyment and excitement of boating there are some basic rules that should be observed and followed by any boater. Some rules may be new to you and others may be common sense or obvious... irrespective, take them seriously!

 Be sure at least one of your passengers knows how to handle your boat in case of an emergency.

 All passengers should know the location of emergency equipment and how to use it.

 Know the marine traffic laws and obey them.

 All safety equipment and personal floatation devices must be in good condition and suitable for your type of boat. Always comply with the regulations that apply to your boat.

 Remember, gasoline fumes are flammable and explosive. Always adhere to the fueling procedure contained in this Operator's Guide and those given to you by the fueling station. Always verify fuel level before use and during the ride. Apply the principle of 1/3 fuel to destination, 1/3 back and 1/3 reserve fuel supply. Do not carry spare fuel or flammable liquids in any storage or engine compartments.

 Whenever running the engine, assure there is proper ventilation to avoid the accumulation of carbon monoxide (CO), which is odorless, colorless, and tasteless, and can lead to unconsciousness, brain damage, or death if inhaled in sufficient concentrations. CO accumulation can occur while docked, anchored, or underway, and in many confined areas such as the boat cabin, cockpit, swim platform, and heads. It can be worsened or caused by weather, mooring and operating conditions, and other boats. Avoid exhaust fumes from your engine or other boats, provide proper ventilation, shut off your engine when not needed, and be aware of the risk of backdrafting and conditions that create CO accumulation. In high concentrations, CO can be fatal within minutes. Lower concentrations are just as lethal over long periods of time.

 Avoid standing up or shifting weight suddenly in light weight boats.

 Keep your passengers seated in seats. The boat's bow, gunwale, transom and seat backs are not intended for use as seats.

SAFETY MEASURES — Installation and Maintenance

 Insist on the use of personal floatation devices, approved by the U.S. Coast Guard, by all passengers when boating conditions are hazardous, and by children and nonswimmers at all times.

 Proceed with caution and at very low speed in shallow water. Grounding or abrupt stops may result in personal injury or property damage. Also be alert for debris and objects in the water.

 Be familiar with the waters you are operating in. The gearcase of this outboard extends below the water surface and could potentially come in contact with underwater obstructions. Contact with underwater obstructions may result in loss of control and personal injury.

 Respect no wake zones, rights of other water users and the environment. As the "skipper" and owner of a boat you are responsible for damage to other boats caused by the wake of your boat. Allow no one to throw refuse overboard.

 Do not operate your boat if you are under the influence of drugs or alcohol.

 High performance boats have a high power-to-weight ratio. If you are not experienced in the operation of a high performance boat, do not attempt to operate one at, or near, its top speed until you have gained that experience.

 Become completely familiar with the control and operation of your boat and outboard before embarking on your first trip or taking on a passenger(s). If you have not had the opportunity to do so with your Dealer, practice driving in a suitable area and feel the response of each control. Be familiar with all controls before applying the throttle above idle speed. As the operator, you are in control and responsible for safe operation.

 The outboard must be correctly installed. Failure to correctly install the outboard could result in serious injury, death or property damage. We strongly recommend that your Dealer install your outboard to ensure proper installation.

 Do not overpower your boat by using an engine that exceeds the horsepower indicated on the boat's capacity plate. Overpowering could result in loss of control. If your boat has no capacity plate, contact your Dealer or the boat's manufacturer.

 When replacement parts are required, use *Evinrude/Johnson Genuine Parts* or parts with equivalent characteristics, including type, strength and material. Using substandard parts could result in injury or product malfunction.

 Only perform service procedures which are detailed in this Operator's Guide. Attempting to perform maintenance or repair on your outboard if you are not familiar with the correct service and safety procedure could cause personal injury or death. Further information can be obtained from your authorized *Evinrude/Johnson* Dealer. In many instances proper tools and training are required for certain service or repair procedures.

 Maintain your boat and engine in top condition at all times. Adhere to the **MAINTENANCE SCHEDULE** on page 43.

 Operate your boat and outboard prudently and have fun. Do not forget that all persons must assist other boaters in case of emergency.

 Prevent injury from contact with rotating propeller; remove propeller before flushing or before performing any maintenance.

PRODUCT REFERENCES, ILLUSTRATIONS AND SPECIFICATIONS

BRP reserves the right to make changes at any time, without notice, to features, specifications and model availability, and to change any specification or part at any time without incurring any obligation to update older models. The information in the Guide is based on the latest specifications available at the time of publication.

Photographs and illustrations used in this Guide might not depict actual models or equipment but are intended as representative views for reference only.

Certain features of systems discussed in this Guide might not be found on all models in all marketing areas.

Owner's Identification

United States and Canada — At the time of purchase, your Dealer will complete your outboard registration forms. Your portion provides proof of ownership and date of purchase.

Outside United States and Canada — See your Dealer or distributor for details.

Model and Serial Numbers

The model and serial numbers appear on a plate attached to the stern bracket or swivel bracket. Record your outboard's:

Model Number _____

Serial Number _____

Purchase Date _____

Ignition Key Number _____

Stolen Outboards

United States and Canada — Report stolen outboards to your local dealer or distributor.

Outside United States and Canada — Report the theft to the Bombardier Recreational Products distributor where the outboard was registered.

Technical Literature

BRP offers technical literature specifically for your outboard. A service manual, a parts catalog, or an extra Operator's Guide can be purchased from your selling Dealer. For the name and location of the nearest *Evinrude* Dealer in the United States and Canada visit www.evinrude.com.

Declaration of Conformity

- **Application of Council Directives:**

Directive 94/25/EC as amended by 2003/44/EC – Recreational-Craft

- **Relevant Directive(s):**

Directive 89/336/EC as amended by 2004/108/EC – Electromagnetic Compatibility

- **Relevant Harmonized Standard(s):**

As referenced by Council and Relevant Directives

- **Product Type:**

Marine Outboard 2-Stroke Cycle SI Engine

- **Manufacturer:**

BRP US Inc.
10101 Science Drive
Sturtevant, WI 53177

EC Type Certificate:

Engine Model(s)	Exhaust Emissions Certificate Number	Sound Emissions Certificate Number
E75DPLIS, E75DSLIS, E90DPLIS, BE90DPLIS, E90DPXIS, BE90DPXIS, E90DSLIS, BE90DSLIS, E90WDELIS, BE90WELIS, E90WDEXIS, BE90WEXIS	EXBOMB003	SDBOBM014

I, the undersigned, hereby declare that the product specified above conforms to the above Directive(s) and Standard(s).



Jean Daunais,

Director, Intellectual Property and Product Compliance



**USING YOUR
EVINRUDE E-TEC
OUTBOARD**

► Using Your E-TEC Outboard

SAFETY INFORMATION ON THE OUTBOARD

This outboard comes with a hang tag and labels containing important safety information about the operation of the outboard. Any person who operates this outboard should read and understand this safety information.

WARNING SYMBOLS

The following symbols are used together to indicate "CAUTION: Read the engine's Operator's Guide before proceeding."

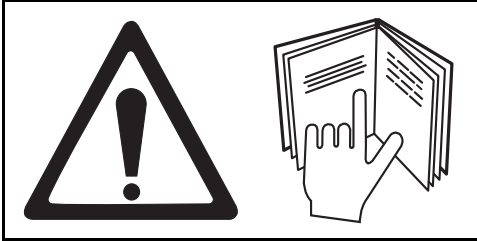

HANG TAG

All outboards are shipped with the following hang tag attached.



REMOTE CONTROL DECALS

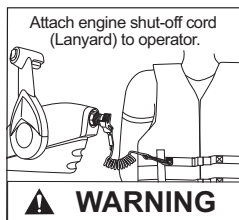
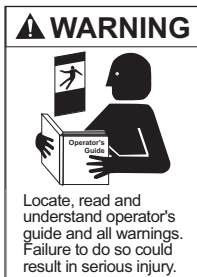

Shift position
Reverse / Neutral / Forward



COMPONENT IDENTIFICATION

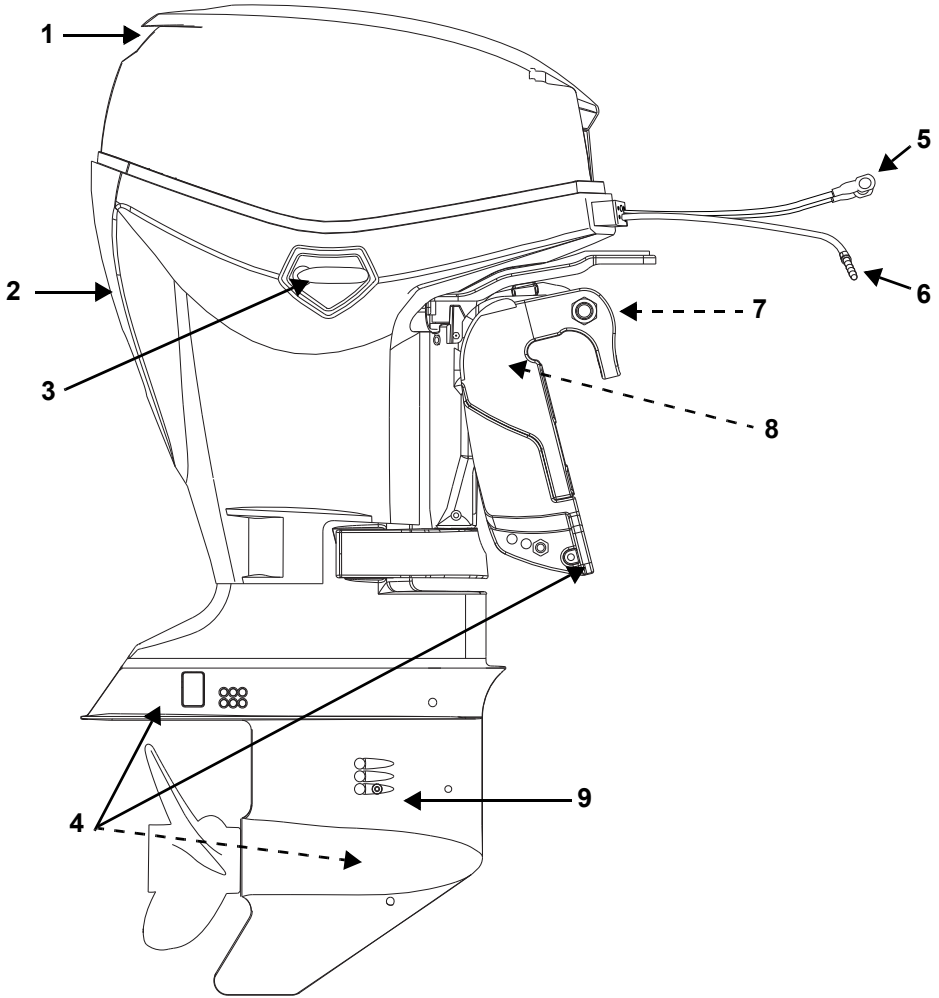

Item	Description	Item	Description
1	Air Inlet, Tilt Handle	6	Fuel Fitting
2	Water Pump Indicator, Flushing Port	7	Tilt Limiter Cam
3	Engine Cover Latch	8	Tilt Support
4	Anti-Corrosion Anodes	9	Water Intake Screens
5	Battery Cables		

Starboard

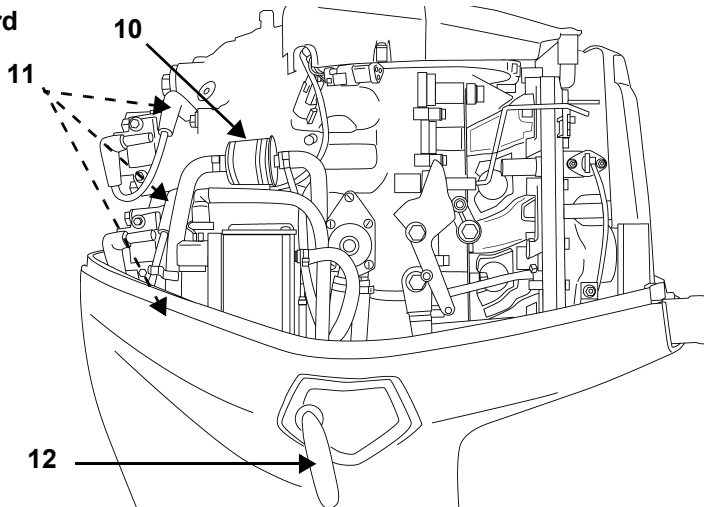

Port

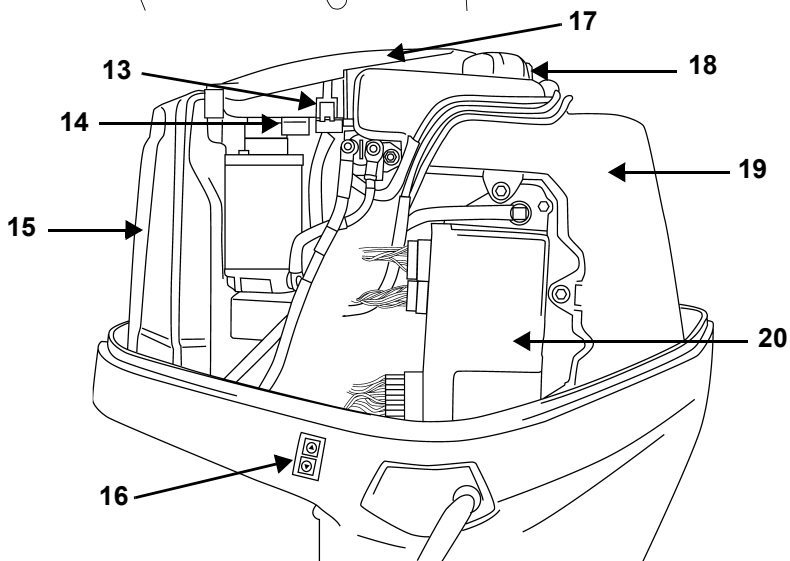

Item	Description	Item	Description
10	Fuel Filter	16	Trawlering Tilt Switch
11	Spark Plugs	17	Flywheel Guard
12	Engine Cover Latch	18	Oil Fill Cap
13	Fuse	19	Oil Tank
14	Spare Fuse	20	EMM (Engine Management Module)
15	Air Silencer		

OIL AND FUEL

OIL REQUIREMENTS



Evinrude/Johnson *Brand Oils*

Evinrude/Johnson outboard oils are formulated to give best engine performance while controlling piston and combustion chamber deposits, providing superior lubrication, and ensuring maximum spark plug life.

The following outboard oils are recommended for use in your Evinrude E-TEC outboard:

- Evinrude/Johnson XD100;
- Evinrude/Johnson XD50; or
- Evinrude/Johnson XD30.

Evinrude/Johnson XD100 Oil

Evinrude/Johnson XD100 oil is preferred for your Evinrude E-TEC outboard. This synthetic formula oil provides uncompromised lubrication and superior performance, even in extreme conditions—especially in cold temperatures down to -17°C (0°F).

If requested, an authorized dealer can program your Evinrude E-TEC outboard EMM for the exclusive use of Evinrude/Johnson XD100. **Only an authorized Evinrude dealer can program your outboard for this optional benefit.**

Oil consumption is reduced if the outboard is programmed for exclusive use of Evinrude/Johnson XD100 as compared to using a conventional oil.

IMPORTANT: If your EMM has been programmed for Evinrude/Johnson XD100, DO NOT use any other oil unless in an emergency. If Evinrude/Johnson XD100 is temporarily unavailable, a one-time-only use of an oil that meets NMMA TC-W3 certification standards is allowed. If you discontinue using Evinrude/Johnson XD100, you MUST first return to your Dealer to have the EMM reprogrammed back to the original factory setting.

Other Oils

If Evinrude/Johnson brand oils are not available, you must use an oil that meets NMMA TC-W3 certification standards.

IMPORTANT: Failure to follow oil specifications could void the engine warranty if a lubrication-related failure occurs.

OILING SYSTEM



If the “LOW OIL” warning light illuminates, you have approximately five hours of normal operation before running out of oil. Refill the oil tank at next convenient opportunity.

Always “top off” your oil tank prior to prolonged usage or long trips.

New outboards are programmed to use additional oil during the first two hours of operation above 2000 RPM.

NOTICE When operating in conditions under 0°C (32°F), Evinrude/Johnson XD100 oil must be used.

Filling the Oil Tank

Release the port and starboard engine cover latches by turning each handle downward.

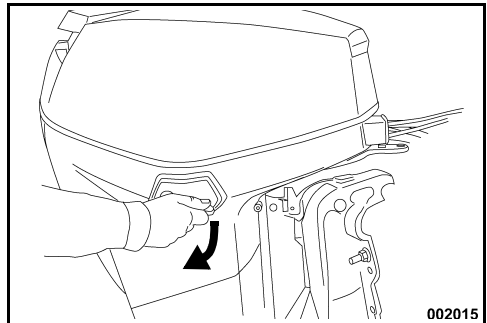

Pull up on the tilt handle to release the engine cover seal on the engine cover.

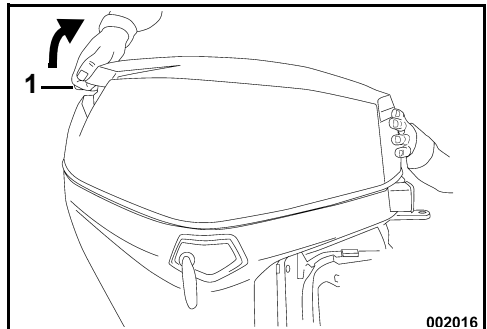

1. Tilt handle

Remove the engine cover to access the oil tank.

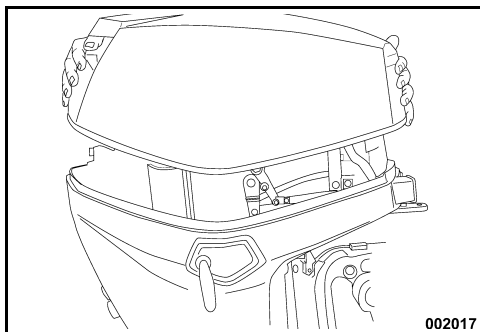

002017

Remove the filler cap and fill the tank with the recommended outboard lubricant, as specified in **OIL REQUIREMENTS** on page 16.

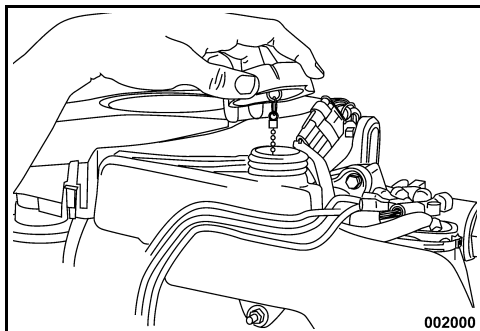

002000

Replace the filler cap and tighten securely. Reinstall the engine cover.

IMPORTANT: The oil tank capacity is 2.8 liters (3.0 quarts).

Priming the Oil System



The oiling system must be primed before using the outboard if:

- The outboard is new (check with your dealer to ensure oil system was primed);
- You run completely out of oil; or
- The outboard is laid down for transportation or storage.

Prime the oiling system by performing winterization. Refer to **LONG-TERM STORAGE (WINTERIZATION)** on page 46.

FUEL REQUIREMENTS

⚠ WARNING

Gasoline is extremely flammable and highly explosive under certain conditions. Follow the instructions in this section explicitly. Improper handling of fuel could result in property damage, serious injury or death.

Leaking fuel is a fire and explosion hazard. All parts in the fuel system should be inspected frequently and replaced if signs of deterioration or leakage are found. Inspect the fuel system each time you refuel, each time you remove the engine cover and annually.

Follow these instructions to ensure safety when handling fuel:

- Always turn off the engine before fueling.
- Never permit anyone other than an adult to refill the fuel tank.
- Do not fill the fuel tank all the way to the top or fuel may overflow when it expands due to heating by the sun.
- Remove portable fuel tanks from the boat before fueling.
- Always wipe off any fuel spillage.
- Do not smoke, or allow open flames, or sparks or use electrical devices such as cellular phones in the vicinity of a fuel leak or while fueling.
- Always work in a well ventilated area.

NOTICE Always use fresh gasoline. Gasoline will oxidize; the result is loss of octane, volatile compounds, and the production of gum and varnish deposits which can degrade the fuel system.

Minimum Octane

Your outboard is certified to operate on unleaded automotive gasoline with an octane rating equal to or higher than:

- 90 RON — Outside the U.S.
- 87 (R+M)/2 AKI — Inside the U.S.

Using unleaded gasoline that contains methyl tertiary butyl ether (MTBE) is acceptable **ONLY** if the MTBE content does not exceed 15% by volume.

► Using Your E-TEC Outboard

Alcohol Fuels

Your outboard has been designed to operate using the specified fuels; however, be aware of the following:

- The boat's fuel system may have different requirements regarding the use of alcohol fuels. Refer to the boat's owner guide.
- Alcohol attracts and holds moisture that can cause corrosion of metallic parts in the fuel system.
- Alcohol blended fuel may cause engine performance problems.

Using alcohol-extended fuels is acceptable **ONLY** if the alcohol content does not exceed:

- 10% ethanol by volume; or
- 5% methanol with 5% cosolvents by volume.

FUEL ADDITIVES

The only fuel additives approved for use in your *Evinrude E-TEC* outboard are:

- *Evinrude/Johnson 2+4 Fuel Conditioner*
- *Evinrude/Johnson Fuel System Cleaner*

Use of other fuel additives can result in poor performance or engine damage.

Evinrude/Johnson 2+4 Fuel Conditioner will help prevent gum and varnish deposits from forming in fuel system components and will remove moisture from the fuel system. It can be used continuously and should be used during any period when the outboard is not being operated on a regular basis. Its use will reduce spark plug fouling, fuel system icing, and fuel system component deterioration.

Evinrude/Johnson Fuel System Cleaner will help keep fuel injectors in optimal operating condition.

FUEL SYSTEM OPERATION

Connecting the Fuel Hose

If the fuel hose is disconnected for any reason, seal it to prevent spillage. Cap the fuel fitting to prevent contamination.

Connect the fuel hose to the 9 mm (3/8 in.) fuel fitting. Fasten hose securely with clamp (18.5 mm) from owner's kit.

Squeeze fuel primer bulb, outlet end up, until firm.

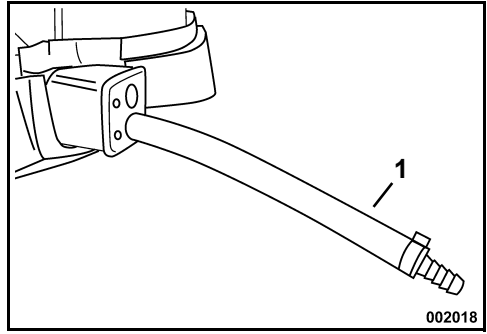

1. Fuel hose and fitting – 9 mm (3/8 in.)

⚠ WARNING

Store fuel tanks in a well-ventilated area, away from heat and open flame. Prevent escape of liquid or vapors which could accidentally ignite.

Close the filler cap vent screw, if equipped.

Be sure the disconnected fuel hose does not drip.

IMPORTANT: Fuel distribution hoses in the boat must deliver fuel at the rate of flow needed by the outboard. Minimum inside diameter of fuel hoses must be 9 mm (3/8 in.).

Fuel systems with built-in tanks, particularly those that include antisiphon valves and filter/primer units, may have restrictions not allowing the engine fuel pump to deliver sufficient fuel under all conditions. This can result in a loss of performance. If a performance problem exists, see your Dealer.

OPERATION

SAFETY INFORMATION

⚠ WARNING

DO NOT run the engine indoors or without adequate ventilation or permit exhaust fumes to accumulate in confined areas. Engine exhaust contains carbon monoxide which, if inhaled, can cause serious brain damage or death.

⚠ DANGER

Contact with a rotating propeller is likely to result in serious injury or death. Assure the engine and prop area is clear of people and objects before starting engine or operating boat.

⚠ WARNING

Do not allow anyone near a propeller, even when the engine is off. Blades can be sharp and the propeller can continue to turn even after the engine is off. Always shut off the engine when near people in the water.

⚠ WARNING

The engine cover is a machinery guard. DO NOT operate your outboard with the cover off unless you are performing maintenance or emergency starting, and then be careful to keep hands, hair, and clothing clear of all moving parts. Contact with moving parts could cause injury.

⚠ Be familiar with the waters you are operating in. The gearcase of this outboard extends below the water surface and could potentially come in contact with underwater obstructions. Contact with underwater obstructions may result in loss of control and personal injury.

ENGINE STARTING

Refer to the [owner's manual](#) for pre-launch checks before using your Evinrude E-TEC outboard.

NOTICE You **MUST** supply water to the engine before attempting to start it. Engine damage can occur quickly.

Be sure the water intake screens are below the water surface.

Emergency Stop/Key Switch

A combination emergency stop switch and key switch is a feature of Evinrude prewired remote controls and all Evinrude control wiring kits.

Connect the clip to the emergency stop/key switch. Snap the lanyard to a **secure** place on the operator's clothing or life vest — not where it might tear away instead of activating the stop switch.

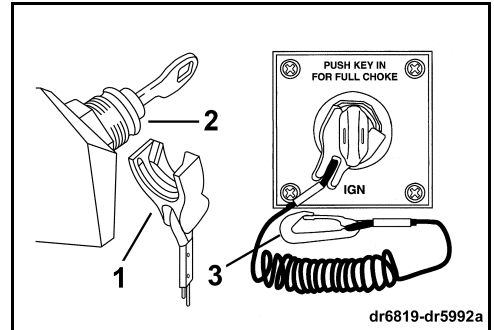

1. Clip
2. Emergency stop / key switch
3. Lanyard

⚠ WARNING

Always use the safety lanyard when operating your boat to help prevent a runaway boat and reduce the risk of personal injury or death.

In an emergency situation, the engine can be started without the clip in place. Follow the normal starting procedure. Reinstall a clip as soon as possible.

IMPORTANT: Your emergency stop switch can be effective only when in good working condition. At each outing, inspect clip and lanyard for cuts, breaks, or wear. Replace worn or damaged parts.

► Using Your E-TEC Outboard

Snap the lanyard to a **secure** place on the operator's clothing or life vest — not where it might tear away instead of activating the stop switch.

Set control to **SLOWEST** speed position.

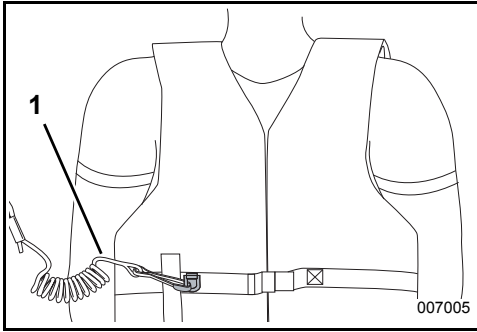

1. Lanyard

Disconnecting the clip and lanyard will stop the engine and prevent the boat from becoming a runaway if the driver moves beyond the range of the lanyard. If the lanyard is too long, it can be shortened by knotting or looping it. **DO NOT** cut and retie the lanyard

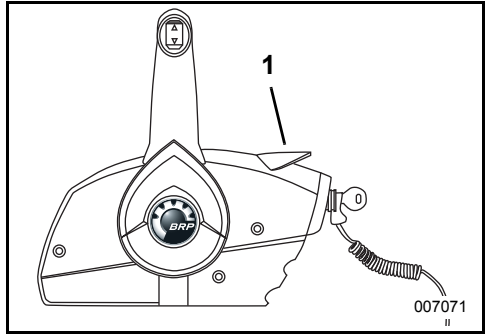

1. **SLOWEST** speed position



DO NOT advance the throttle before start-up. Advancing the throttle overrides the electronic idle control system. After the engine starts, the engine management module (EMM) automatically increases idle speed slightly. Idle speed will decrease as the engine warms up. The engine monitor gauge lights or display will illuminate if the throttle is advanced.

⚠ WARNING

Avoid knocking or pulling the clip off the stop switch during normal boating. The resulting unexpected loss of forward motion can throw occupants forward, causing injury.

Keep the lanyard free from obstructions and entanglements.

At each outing, test the system's operation. With the engine running, remove the clip from the switch by pulling the lanyard. If the engine does not stop running, see your Dealer.

NOTICE Carefully check the function of all control and engine systems before leaving the dock. **DO NOT** shift the engine into **FORWARD** or **REVERSE** while it is shut off.

If the following directions are not suitable for your boat's control, see your Dealer before proceeding.

Move the remote control handle to **NEUTRAL**.

⚠ WARNING

If you are using a remote control that does not have start-in-gear prevention, the outboard can be started while it is in gear. Protect against unexpected boat movement by always starting your outboard in **NEUTRAL**.

⚠ WARNING

Always shift to **NEUTRAL** before starting the outboard to prevent sudden boat movement, which can cause injury.

Starting

Turn the key switch fully clockwise to the START position.

NOTICE The starter motor can be damaged if operated continuously for more than 20 seconds.

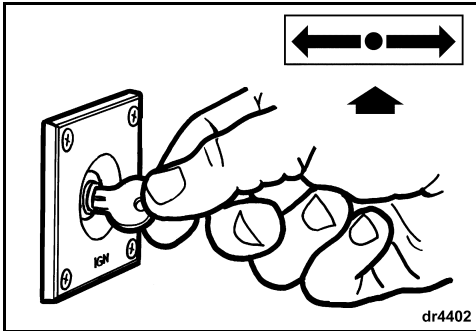

Upon start-up, release the key.

If the engine did not start, release the key momentarily, then try again.

Each time the key switch is turned from OFF to ON, the warning system will self-test. Refer to **ROUTINE INSPECTION CHECKLIST** on page 40. If the warning system fails to self-test during start-up, see your Dealer.

If your outboard does not react normally to this starting procedure or if it fails to start, refer to **TROUBLESHOOTING** on page 50.

After Engine Starts

Check the water pump indicator. A steady stream of water indicates the water pump is working. If a steady stream of water from the water pump indicator is not visible, stop the engine. Refer to **ENGINE OVERHEATING** on page 39.

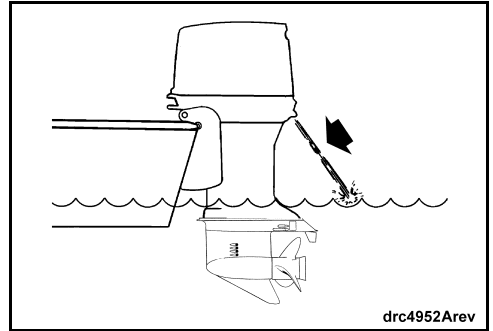

Engine Stopping

Move control handle to NEUTRAL.

Turn key switch counterclockwise to the OFF position.

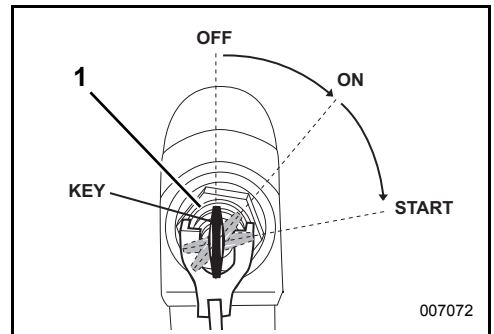

1. Key switch, OFF position

Remove the key when the boat will be unattended. If equipped, close the vent screw on the fuel tank's filler cap.

► Using Your E-TEC Outboard

EMERGENCY STARTING

If the starter fails, your engine can be started using a 1/4 in (6 mm) cord about 1.2 m (4 ft.) long.

⚠ WARNING

Move the shift lever to NEUTRAL before performing emergency starting procedures. Failure to do so may result in unexpected boat movement.

The engine cover is a machinery guard. To prevent injury from moving engine components, keep hands, clothes, and hair clear of powerhead.

Prevent electric shock by keeping clear of the ignition coils and spark plug leads when the outboard is being started or is running. Shock can cause serious personal injury under certain conditions.

DO NOT turn flywheel by hand. Use starter cord only.

Be sure:

- Key switch is OFF.
 - Engine is in normal operating position.
 - Shift lever is in NEUTRAL.
- 1) Release port and starboard side engine cover latches downward. Pull up on the tilt handle to release the engine cover seal and remove the engine cover.

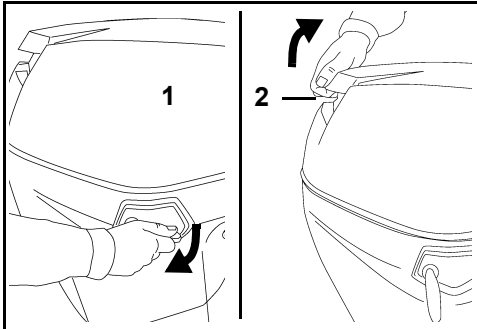

1. Engine cover latch
2. Tilt handle

- 2) Remove fuse holder from flywheel cover.

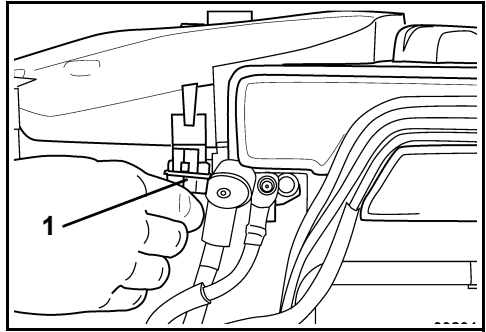

1. Fuse

- 3) Raise flywheel guard from the fittings by pulling up on the front two fastening tabs.

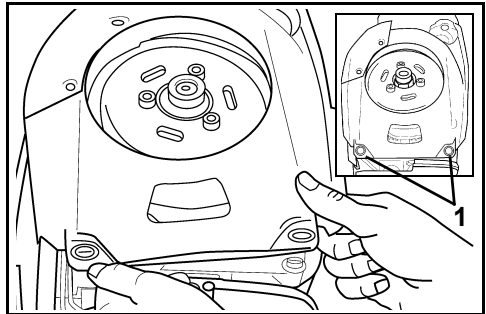

1. Fastening tabs

- 4) Holding the flywheel guard out of the way, hook the knot of your emergency start cord into the notch on the flywheel. Wind the cord clockwise in the flywheel ridge, making one and a half full windings with the cord.

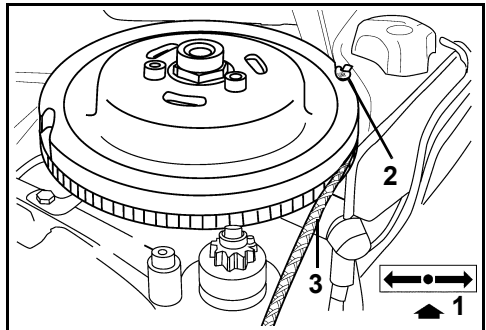

1. NEUTRAL
2. Knot
3. Rope in flywheel ridge

- 5) Turn key switch ON.
- 6) From a secure position in the boat, pull hard on emergency starting cord to start engine.

⚠ CAUTION

Keep everyone clear of your immediate area when pulling on emergency starting cord, especially behind you.

Repeat procedure, if necessary, until engine starts.

- 7) Refasten flywheel guard in place by pushing the three fastening tabs back onto the fittings.

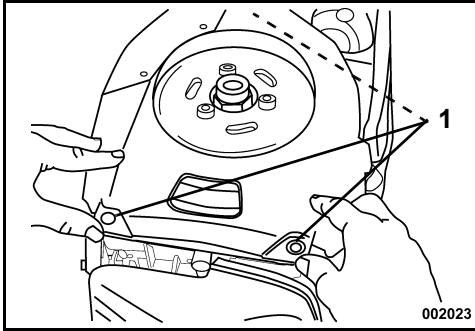

1. Fastening tabs

⚠ DANGER

Contact with a rotating flywheel can cause severe personal injury. Use extreme care in re-fastening the flywheel guard on the fastening tabs. Keep hands, hair, and clothing away from coming in direct contact with rotating parts.

If equipped, snap emergency stop switch lanyard to secure place on clothing. Proceed immediately to nearest landing for service.

REMOTE CONTROLS

⚠ WARNING

If you choose a non-Evinrude remote control, it must have a start-in-gear prevention feature. This feature can prevent injuries resulting from unexpected boat movement when the engine starts.

IMPORTANT: When selecting the remote control system for your boat, specify *Evinrude* components. *Evinrude* controls deliver the cable stroke your outboard needs for positive shift and throttle control, and they incorporate such safety and convenience features as:

- Start-in-gear prevention
- Plug-in compatibility with *Evinrude* Modular Wiring System (MWS)

Side Mount Control

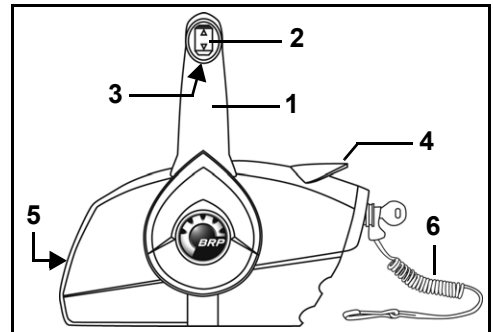

1. Handle – shift and throttle
2. Trim/tilt switch (where equipped)
3. Neutral lock lever
4. Fast idle lever (warm-up)
5. Throttle friction adjusting screw
6. Emergency stop clip and lanyard

► Using Your E-TEC Outboard

Concealed Side Mount Control

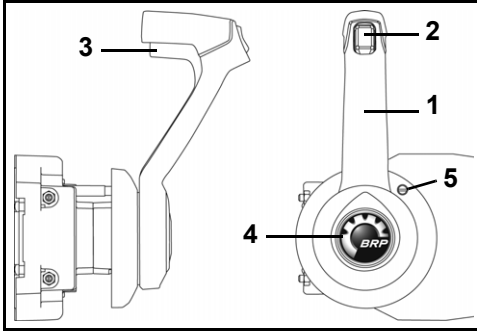

1. Handle – shift and throttle
2. Trim/tilt switch (where equipped)
3. Neutral lock lever
4. Fast idle button (warm-up)
5. Throttle friction adjusting screw

Dual Lever Binnacle Mount Control

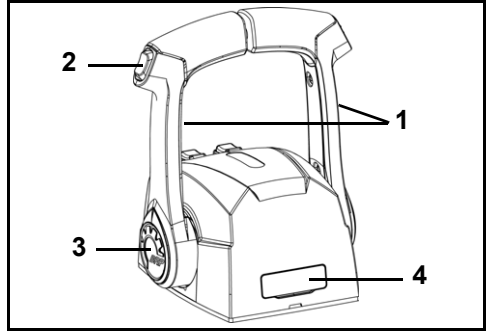

1. Handle – shift and throttle
2. Trim/tilt switch (where equipped)
3. Fast idle button (warm-up)
4. Throttle friction adjusting screw (under cover)

Single Lever Binnacle Mount Control

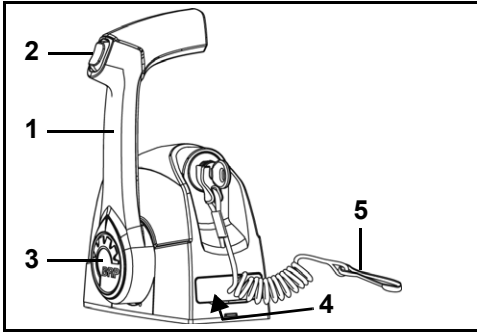

1. Handle – shift and throttle
2. Trim/tilt switch (where equipped)
3. Fast idle button (warm-up)
4. Throttle friction adjusting screw (under cover)
5. Emergency stop clip and lanyard

SHIFTING AND SPEED CONTROL

IMPORTANT: Carefully check the function of all control and engine systems before leaving the dock. DO NOT shift the engine into FORWARD or REVERSE while it is shut off.

⚠ WARNING
Always use the safety lanyard when operating your boat to help prevent a runaway boat and reduce the risk of personal injury or death.

⚠ WARNING
 Avoid knocking or pulling the clip off the stop switch during normal boating. Avoid bumping the key if operating without the clip on the switch. The resulting unexpected loss of forward motion can throw occupants forward, causing injury.
 Keep the lanyard free from obstructions and entanglements.
 At each outing, test the system's operation. With the engine running, remove the clip from the switch by pulling the lanyard. If the engine does not stop running, see your Dealer.

NOTICE Carefully check the function of all control and engine systems before leaving the dock. DO NOT shift the engine into FORWARD or REVERSE while it is shut off.

If the following directions are not suitable for your boat's control, see your Dealer before proceeding.

Shifting

NOTICE When shifting from FORWARD to REVERSE or from REVERSE to FORWARD, pause at NEUTRAL until the engine is at idle speed and the boat has slowed.

With engine running and control handle in NEUTRAL:

Side Mount Controls:

Unlock the control handle by lifting the neutral lock lever on the hand grip. With a firm, quick motion, move the control handle fore or aft until it engages the forward or reverse gear detent.

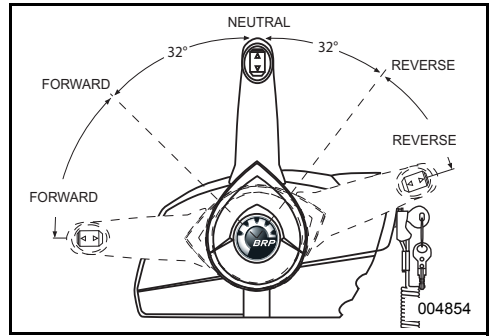

Binnacle Mount Controls:

With a firm, quick motion, move the control handle fore or aft until it engages the forward or reverse gear detent.

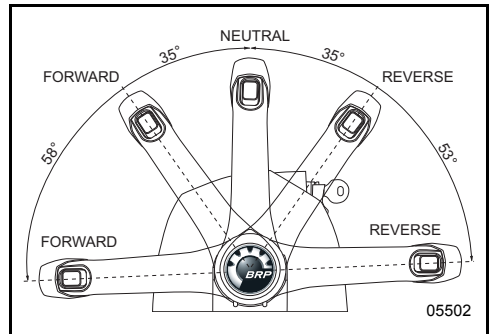

Speed Control

After gear engagement, move the control handle slowly in the same direction to increase speed.

FUEL ECONOMY

Fuel economy can vary depending on boat load, hull design, and throttle setting. When boat reaches top speed, throttle back from FULL SPEED to a lower throttle setting. You will save fuel with a minimal loss of speed.

► Using Your E-TEC Outboard

POWER TRIM AND TILT

⚠ WARNING

Any malfunction of the power trim and tilt unit could result in loss of shock absorber protection if an underwater obstruction is hit. Malfunction can also result in loss of reverse thrust capability.

Correct fluid level must be maintained to ensure operation of the impact protection on this unit.

When operating in rough water or crossing a wake, excessive bow-up trim may result in the boat's bow suddenly rising skyward, possibly ejecting or otherwise seriously injuring occupants.

Some boat/outboard/propeller combinations may encounter boat instability and/or high steering torque when operated at high speed at or near the outboard's trim range limits (full bow-up or bow-down). Boat stability and steering torque can also vary due to changing water conditions. If any adverse conditions occur, reduce throttle and/or adjust trim angle to maintain control. If you experience boat instability and/or high steering torque, see your Dealer to correct these conditions.

Some boats plow, or are difficult to plane, when operated in the trim's lowest position. If your boat handles unsuitably when trimmed fully bow-down, adjust transom angle or limit the travel of the power trim.

⚠ WARNING

If the bow of the boat plows the water at high speeds, the boat may bow steer or spin suddenly, possibly ejecting or otherwise seriously injuring occupants.

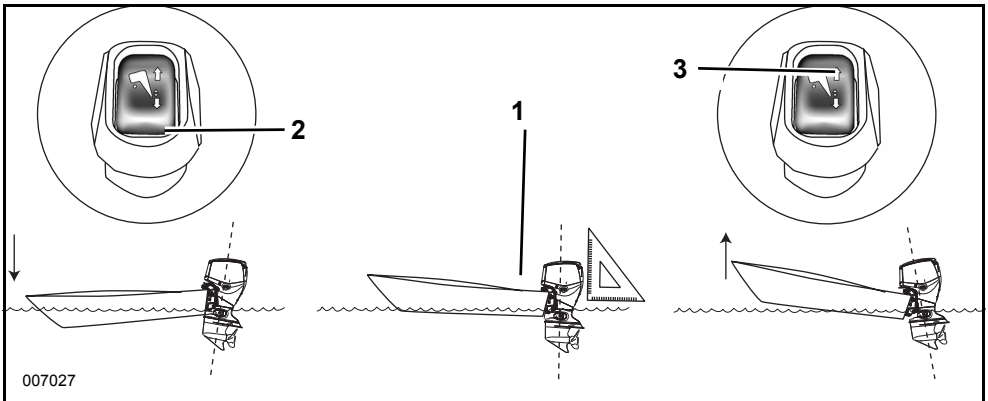

1. Parallel to surface of the water
2. Trim switch, DOWN
3. Trim switch, UP



Trim

In most operating conditions, it is recommended to **trim** the outboard to the full down position when accelerating. Once on plane, trim the outboard up for best performance.

Over-trimming increases engine RPM while decreasing speed. The best trim setting is when the highest speed is achieved with the lowest engine RPM.

Shallow Water Drive

You can **tilt** the outboard to any position within the tilt range but **DO NOT** run the engine faster than idle speed. If idling a tilted outboard, keep its water intakes submerged at all times.

Tilt

The full tilt is often used to tilt the outboard for clearance when beaching, mooring, or launching.

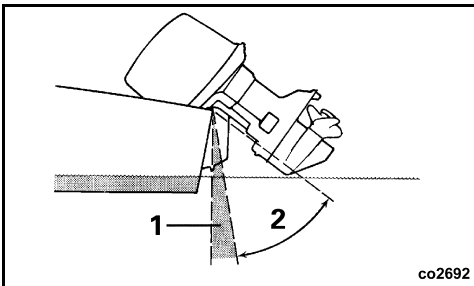

- 1. Trim range
- 2. Tilt range

If the tilted outboard's cover contacts the boat's motor well, limit the maximum tilt by following the procedures in **Tilt Limiter Cam** on page 56.

Tilt Lock Lever

IMPORTANT: DO NOT use the tilt lock lever while trailering. Refer to **TRAILERING** on page 31.

If you intend to leave the outboard tilted for a period of time, engage the tilt lock lever:

- 1) Tilt the outboard UP using the trailering tilt switch.
- 2) Flip the tilt lock lever down.
- 3) Lower the outboard until the tilt lock lever rests solidly on the stern brackets.

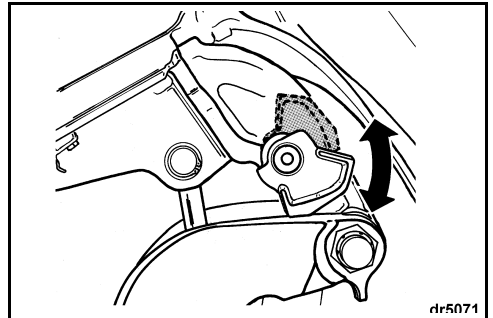

When you are finished tilting the outboard, disengage the tilt lock lever:

- 1) Tilt the outboard UP.
- 2) Flip the tilt lock lever up.
- 3) Lower the outboard to operating position.

► Using Your E-TEC Outboard

Manual Release Valve

If needed, the outboard will tilt up or down manually, using the manual release valve.

⚠ WARNING

Keep everyone clear of a tilted outboard when backing out the manual release screw. The outboard could drop suddenly and forcibly. Be sure to tighten the manual release screw after manually repositioning the outboard. Tightening the screw also reactivates the outboard's impact protection and reverse thrust capability.

- 1) Turn the manual release valve counterclockwise, slowly (about 3 1/2 turns), until it **lightly** contacts its retaining ring.
- 2) Reposition the outboard.
- 3) Tighten the manual release valve to hold the outboard in its new position.

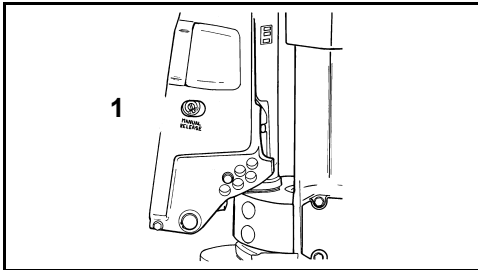

1. Manual release valve

TILTING AND TRIM ADJUSTMENT – MANUAL TILT

⚠ WARNING

When operating in rough water or crossing a wake, excessive bow-up trim may result in the boat's bow suddenly rising skyward, possibly ejecting or otherwise seriously injuring occupants.

Some boat/outboard/propeller combinations may encounter boat instability and/or high steering torque when operated at high speed at or near the outboard's angle adjustment limits (full bow-up or bow-down). Boat stability and steering torque can also vary due to changing water conditions. If any adverse conditions occur, reduce throttle and/or adjust outboard angle adjustment trim angle to maintain control. If you experience boat instability and/or high steering torque, see your dealer to correct these conditions.

If the bow of the boat plows the water at high speeds, the boat may bow steer or spin suddenly, possibly ejecting or otherwise seriously injuring occupants.

Tilting

IMPORTANT: Use the tilt grip to tilt your outboard.

Tilt UP: Move tilt/run lever to TILT position.

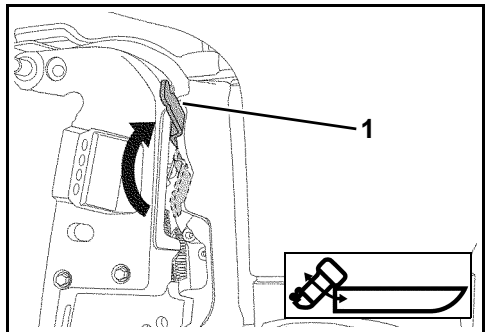

1. TILT position

Grasp tilt grip on engine cover and tilt outboard to the full tilt position.

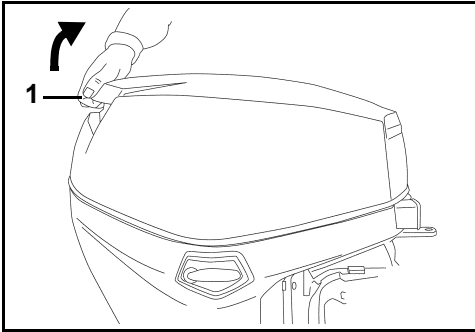

1. Tilt grip

Tilt support brackets will automatically engage.

⚠ WARNING

While outboard is tilted, leave tilt lock lever in the **TILT** position. When the tilt/run lever is in the **RUN** position, tilt support bracket can release unexpectedly and allow outboard to drop, creating a risk of serious personal injury or loss of control.

Tilt DOWN: Move tilt/run lever to RUN position.

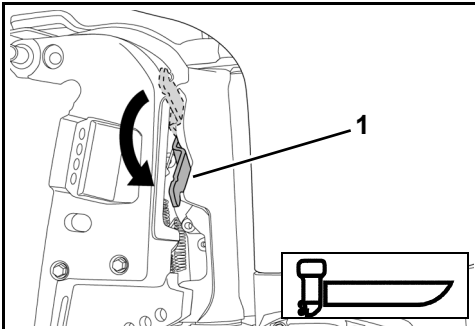

1. RUN position

Grasp tilt grip on engine cover and raise outboard slightly. Tilt support brackets will automatically disengage. Slowly lower outboard to its normal operating position.

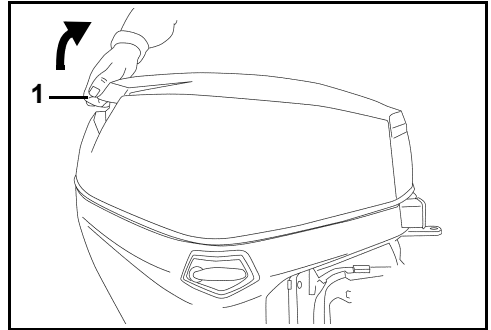

1. Tilt grip

Tilt Lock Lever

IMPORTANT: DO NOT use the tilt lock lever while trailering. Refer to **TRAILERING** on page 31.

If you intend to leave the outboard tilted for a period of time, engage the tilt lock lever:

- 1) Tilt the outboard UP using the trailering tilt switch.
- 2) Flip the tilt lock lever down.
- 3) Lower the outboard until the tilt lock lever rests solidly on the stern brackets.

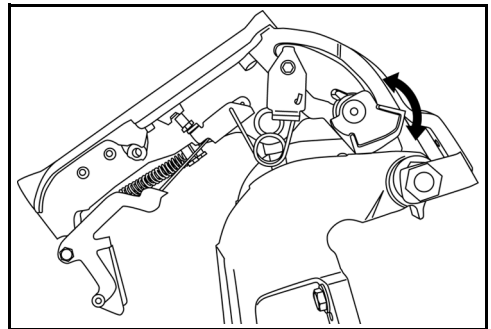

When you are finished tilting the outboard, disengage the tilt lock lever:

- 1) Tilt the outboard UP.
- 2) Flip the tilt lock lever up.
- 3) Lower the outboard to operating position.

► Using Your E-TEC Outboard

Outboard Angle Adjustment

⚠ WARNING

Boat stability and steering torque can vary due to changing water conditions. If any adverse conditions occur, reduce throttle and/or adjust tilt angle to maintain control. If you experience boat instability and/or high steering torque, see your Dealer to correct these conditions.

If the bow of the boat plows the water at high speeds, the boat may bow steer or spin suddenly, possibly ejecting or otherwise seriously injuring occupants.

The outboard should be perpendicular to the water when the boat is underway at full speed. This adjustment can only be determined by water testing the boat. Set angle adjustment for your normal load.

- Place the outboard in full TILT position. Refer to **TILTING AND TRIM ADJUSTMENT – MANUAL TILT** on page 28.
- Turn the angle adjusting rod handle up. Push in against spring so retainer will release, then slide rod assembly all the way out.
- Insert rod in desired position. Make sure rod passes through both stern brackets.
- Push in against spring and turn rod handle down. Make sure the retainer dropped into lock position.

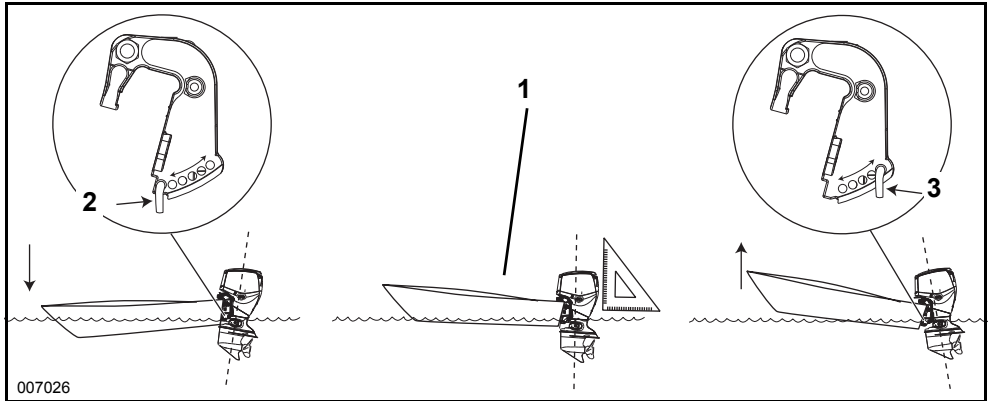

007026

1. Parallel to the surface of the water
2. Tilt pin, DOWN
3. Tilt pin, UP

TRAILERING

Power Trim and Tilt Models

⚠ WARNING
 Keep everyone clear of stern area when raising or lowering the outboard. Personal injury or death can result from contact with moving parts of the outboard.

To engage trailering bracket, tilt the outboard fully using the tilt switch inside the boat or the trailering tilt switch (on port side of engine).

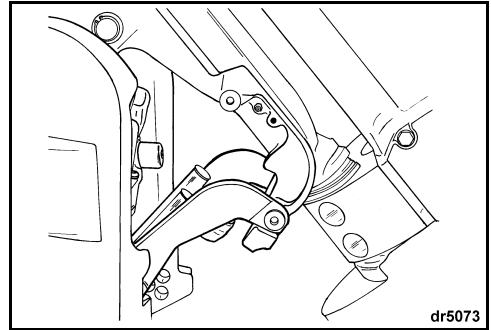

To disengage bracket — Tilt the outboard fully. Return the trailering bracket to its stowed position. Lower the outboard to its vertical position.

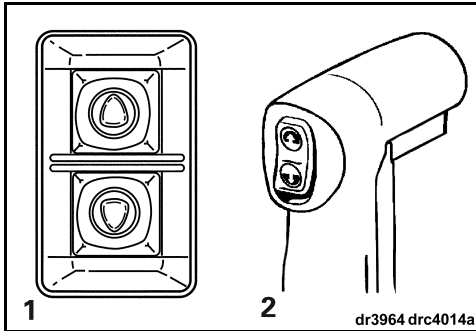

1. Trailering tilt switch
2. Tilt switch inside boat

Pull down the trailering bracket. A detent will hold the bracket in position. Lower the outboard until the trailering bracket locks into place in the stern brackets.

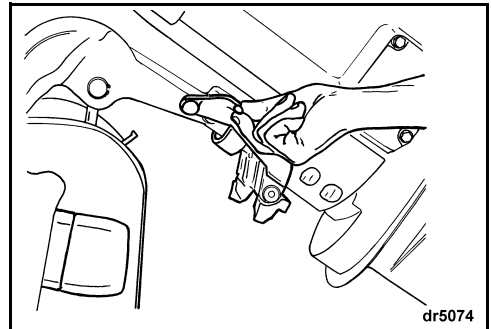

The outboard is designed to be trailered in a vertical position or tilted, using the trailering bracket. Use the position best suited for your boat.

Manual Tilt Models

Trailer your boat with the outboard in a vertical position. If your trailer does not provide adequate road clearance, the outboard can be trailered by using an accessory trailering bracket.

IMPORTANT: Whenever using an accessory trailering bracket, the outboard must be restrained. Bouncing during transport will damage the outboard and boat's transom.

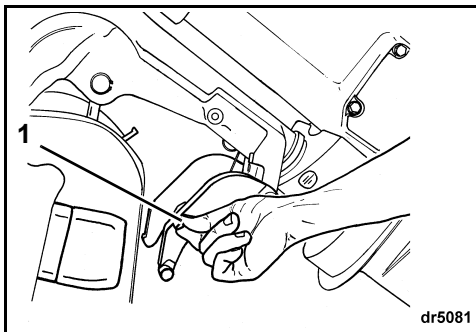

1. Trailering bracket

► Using Your E-TEC Outboard

IMPACT DAMAGE

Your outboard has a shock absorption system designed to help withstand damage from impact with underwater objects at low to moderate speeds. High speed impacts with rigid underwater objects like pilings or boulders can be beyond the capability of the absorption system. Such impacts can result in serious damage to your outboard and injury to boat occupants from the outboard or its parts entering the boat. Occupants can also be ejected or injured by falling against portions of the boat as a result of rapid deceleration following impacts.

When boating in unfamiliar, shallow, or debris-laden waters, seek information on safe boating areas and navigation hazards from a reliable local source. Reduce your speed and keep a sharp lookout!

IMPORTANT: Impact damage is NOT covered by the outboard warranty.

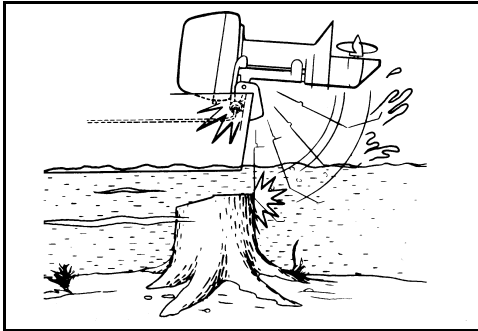

If the collision occurred in the water, proceed slowly to harbor. Before boating again, have your Dealer thoroughly inspect all components.

! WARNING

Failure to inspect for damage after an accident or striking an object could result in sudden, unexpected component failure, loss of boat control, and personal injury. Unrepaired damage could reduce your boat and outboard's ability to resist future impacts.

NOTICE The outboard's shock absorption system does not work while operating in reverse. If you back into an object, either in the water or while trailering, your boat and outboard can be seriously damaged.

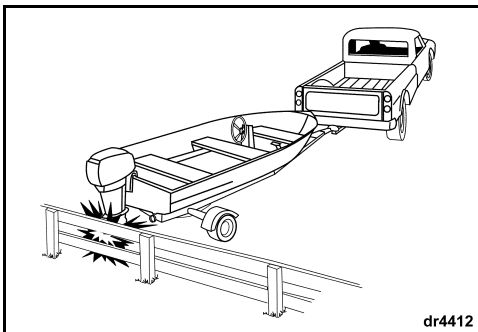

dr4412

If you hit any object:

- STOP immediately and examine the outboard for loosening of attaching hardware.
- INSPECT for damage to swivel and stern brackets, and steering components.
- EXAMINE the boat for structural damage.
- TIGHTEN any loosened hardware.

EMERGENCY STARTING

If the starter fails, your engine can be started using a 6 mm (1/4 in) cord about 1.2 m (4 ft.) long.

⚠ WARNING

Move the shift lever to **NEUTRAL** before performing emergency starting procedures. Failure to do so may result in unexpected boat movement.

The engine cover is a machinery guard. To prevent injury from moving engine components, keep hands, clothes, and hair clear of powerhead.

Prevent electric shock by keeping clear of the ignition coils and spark plug leads when the outboard is being started or is running. Shock can cause serious personal injury under certain conditions.

DO NOT turn flywheel by hand. Use starter cord only.

Be sure:

- Key switch is OFF.
 - Engine is in normal operating position.
 - Shift lever is in **NEUTRAL**.
- 1) Release port and starboard side engine cover latches downward. Pull up on the tilt handle to release the engine cover seal and remove the engine cover.

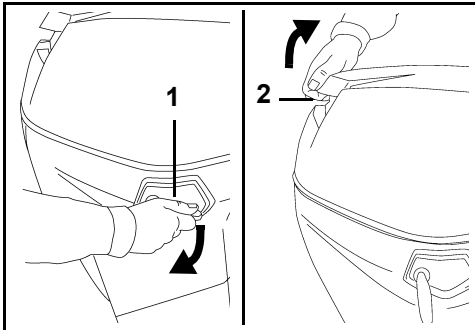

1. Engine cover latch
 2. Tilt handle
- 2) Remove fuse holder from flywheel cover.

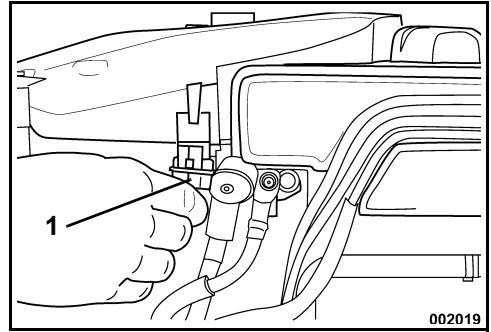

1. Fuse
- 3) Raise flywheel guard from the fittings by pulling up on the front two fastening tabs.

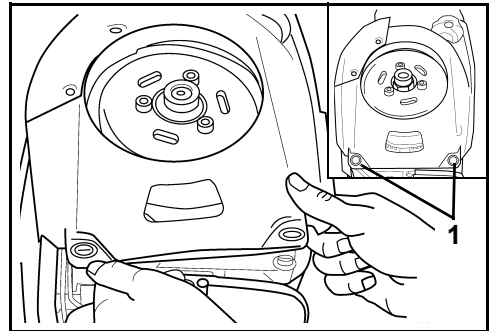

1. Fastening tabs
- 4) Holding the flywheel guard out of the way, hook the knot of your emergency start cord into the notch on the flywheel. Wind cord clockwise in the flywheel ridge, making one and a half full windings with the cord.

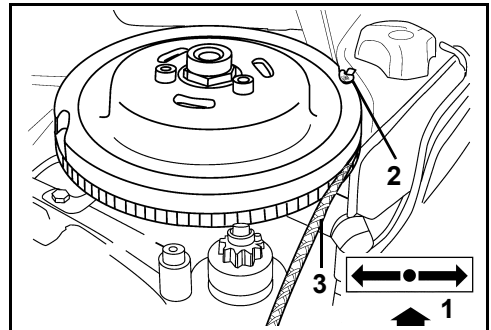

1. NEUTRAL
2. Knot
3. Rope in flywheel ridge
- 5) Turn key switch ON.
- 6) From a secure position in the boat, pull hard on emergency starting cord to start engine.

► Using Your E-TEC Outboard

CAUTION

Keep everyone clear of your immediate area when pulling on emergency starting cord, especially behind you.

Repeat procedure, if necessary, until engine starts.

- 7) Refasten flywheel guard in place by pushing the three fastening tabs back onto the fittings.

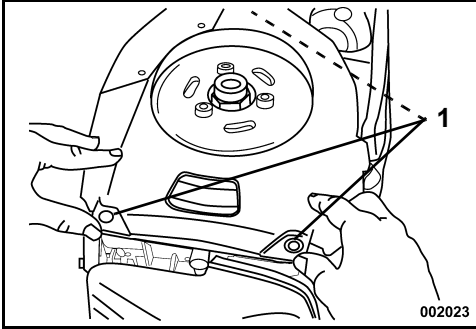

1. Fastening tabs

DANGER

Contact with a rotating flywheel can cause severe personal injury. Use extreme care in re-fastening the flywheel guard on the fastening tabs. Keep hands, hair, and clothing away from coming in direct contact with rotating parts.

If equipped, snap emergency stop switch lanyard to secure place on clothing. Proceed immediately to nearest landing for service.

SPECIAL OPERATING CONDITIONS

SALT WATER

Additional anodic protection for the outboard has been provided for use in salt or brackish water.

Upon removal from salt water, leave outboard in a vertical position until its cooling system has drained. During long periods of mooring, tilt the gearcase out of the water, except in freezing temperatures. Flush the outboard, if desired. Refer to **SHORT-TERM STORAGE** on page 46.

Salt Water Lubrication Points

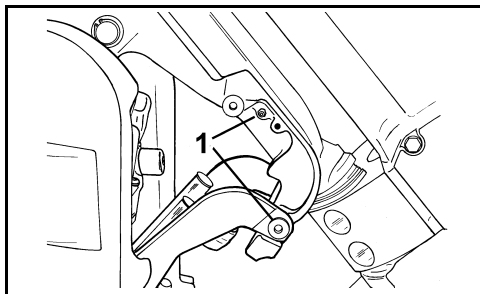

1. Power trim and tilt models, trailing bracket and swivel bracket lubrication points (annually)

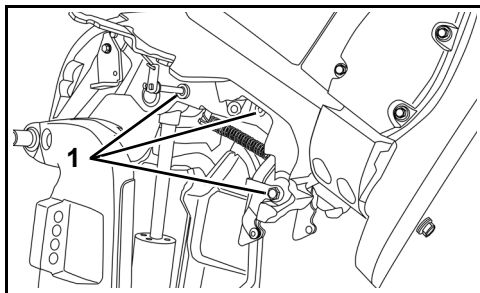

1. Manual tilt models, swivel bracket lubrication points (annually)

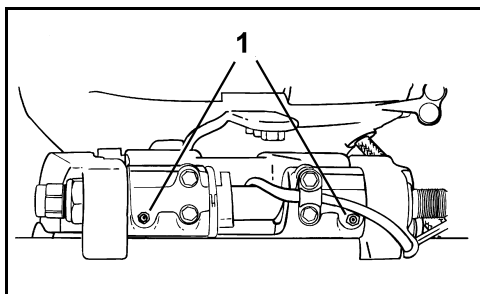

1. Tilt tube lubrication points (annually)

Anti-Corrosion Anodes

Your outboard is equipped with one or more anodes that protect it from galvanic corrosion. Disintegration of the anode is normal and indicates it is working. Check each anode periodically. Replace anodes smaller than 2/3 their original size. See your Dealer for replacements.

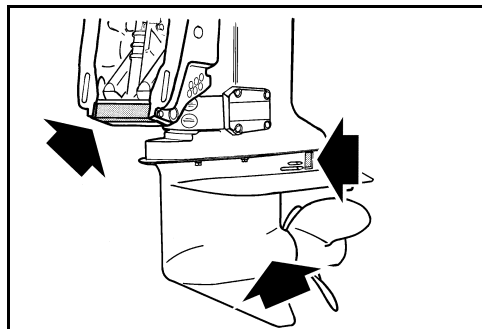

Galvanic corrosion destroys underwater metal parts and can occur in fresh or salt water; however, salt, brackish, and polluted waters will accelerate corrosion.

Metal-based antifouling paint on the boat or outboard and the use of improperly installed shore power in the area of your moored boat will also accelerate corrosion.

IMPORTANT: NEVER paint the anode, its fasteners, or its mounting surface. Painting will reduce its corrosion protection.

► Using Your E-TEC Outboard

WEEDY WATER

Weeds block water intakes and may cause your outboard to overheat. Weeds on the propeller create vibration and reduce boat speed.

When operating in weedy water, run at slow speeds and in REVERSE frequently to clear weeds from the propeller and water intakes. Check the water pump indicator often.

If REVERSE operation does not clear away weeds, SHUT OFF the engine. Remove weeds from propeller area and water intakes before operating at higher speed.

SHALLOW WATER

Gearcase damage can occur if the gearcase is allowed to drag on the waterway bottom. Use caution when operating in shallow water.

Impact damage is NOT covered by the outboard warranty.

UNDER TOW

Should you require a tow from another boat:

- Shift your engine to NEUTRAL;
- Tilt its gearcase out of the water;
- Off-load all persons into another boat; and
- Keep speed slower than planing speed.

DUAL OUTBOARD OPERATION

When in reverse above slow speed, be sure both outboards are running, even if one is in NEUTRAL.

If it is necessary to return to harbor with one outboard not running, tilt the inoperative outboard high enough to keep its propeller out of the water.

FREEZING WEATHER

NOTICE When operating in conditions under 0°C (32°F), *Evinrude/Johnson XD100* oil, must be used.

During operation in freezing weather, keep the gearcase submerged at all times.

Upon removing your outboard from the water, leave it in a vertical position until its cooling system is drained. Store the outboard vertically.

If the outboard's gearcase is equipped with an integral speedometer pickup, all water must be cleared from the hose to prevent gearcase damage. Refer to **STORAGE** on page 46.

NOTICE Water remaining in the gearcase, cooling system or other components can freeze, causing serious engine damage.

HIGH ALTITUDE

Your outboard's *EMM* will automatically compensate for changes in altitude. However, if you boat above 900 m (3000 ft.), you will experience a slight loss of power due to reduced air density.

If your engine drops below the recommended RPM operating range at full throttle, have your Dealer select a lower pitch propeller.

If you return to sea level, have your Dealer install the original propeller and verify correct RPM operating range.

ENGINE MONITORING

IMPORTANT: Your outboard may be equipped with an optional engine monitoring system such as *I-Command*, *SystemCheck*, or equivalent.

The engine monitoring system warns you of conditions that could damage your outboard. The monitoring system consists of a dashmounted gauge, a warning horn, sensors on the engine and oil tank, and related wiring.

The system is compatible with the *Evinrude* Modular Wiring System (MWS) or can be connected to an *I-Command* system, or other NMEA 2000 compliant CANbus instruments.

GAUGES

Gauges are available in several styles, such as a digital *I-Command* gauge with LCD displays or a basic *SystemCheck* gauge.

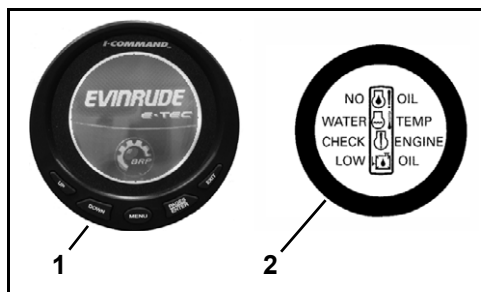

1. Typical *I-Command* Digital gauge
2. Typical *SystemCheck* gauge

Function

The *EMM* activates the warning horn and the gauge displays as follows:

- **LOW OIL** means that oil in the tank is at reserve level (about 1/4 full).
- **NO OIL** indicates an oil delivery problem such as an empty oil tank or damaged oil system.
- **WATER TEMP** or **HOT** indicates an engine or *EMM* overheat condition.
- **CHECK ENGINE** or **FAULT** is used to indicate other fault conditions identified by the *EMM*.

For *I-Command* and other gauges, refer to the gauge user's guide for gauge displays, operation, warnings, and monitoring instructions.

SYSTEM SELF-TEST

During engine start-up, pause with the key switch in the ON position. The monitoring system self-tests by sounding a half-second beep. *SystemCheck* gauges self-test by turning the indicator lights on simultaneously, then off in sequence.

IMPORTANT: If the self-test does not happen as stated, see your Dealer.

ENGINE MONITOR WARNINGS

Engine monitor system warnings activate the horn for 10 seconds and the appropriate gauge light for a minimum of 30 seconds, or until alarm is acknowledged. If the failure is momentary (for example, oil moving in the tank), the engine monitor gauge light or display may remain ON for a full 30 seconds before going out. If the unsafe operating condition continues, a light or display remains ON until the key is turned OFF or the failure is corrected.

The warning will reoccur at the next startup if the problem is not corrected.

If the *EMM* senses a problem could cause permanent engine damage, it will also limit engine speed to 1200 RPM. This additional protection feature is referred to as *S.A.F.E.* (Speed Adjusting Failsafe Electronics). If the engine was running faster than 1200 RPM when the *S.A.F.E.* mode activated, it will shake noticeably. Under certain operating conditions the *EMM* will shut OFF the engine.

⚠ WARNING

In the *S.A.F.E.* mode, the engine speed is limited. Under certain conditions, the engine's limited speed may reduce maneuverability of your boat.

If the *S.A.F.E.* mode is activated and you are unable to correct the problem, seek assistance and/or return to safe harbor. Serious engine damage, engine shutoff, and/or reduced maneuverability may be imminent.

► Using Your E-TEC Outboard

The following warnings may appear on the engine monitor gauge.

“LOW OIL”

Symptom	Oil in the oil tank is at reserve level (about 1/4 full)
Result	<i>EMM</i> will activate low oil light or display warning
Action	<ul style="list-style-type: none">• Fill the oil tank with recommended oil as soon as possible to avoid emptying the tank. The outboard has approximately five hours (ten hours if using <i>Evinrude/Johnson XD100</i> oil) of normal running time before “NO OIL” condition occurs. Refer to Filling the Oil Tank on page 16.

“NO OIL”

Symptom	There is an oil delivery problem.
Result	<i>EMM</i> will activate <i>S.A.F.E.</i> * mode
Action	<ul style="list-style-type: none">• If the oil tank is empty, add the recommended oil.• If the oil tank is not empty, seek assistance and/or return to safe harbor.

Your outboard is designed to run in “get home” mode for up to five hours in the event you run out of oil. See “ENGINE MONITOR WARNINGS” on page 37. Refill the oil tank. Prime oil system. See “Priming the Oil System” on page 17.

“WATER TEMP” or “HOT”

Symptom	The engine is overheating
Result	<i>EMM</i> will activate <i>S.A.F.E.</i> * mode
Action	<ul style="list-style-type: none">• A continuous light with <i>S.A.F.E.</i> mode — The <i>EMM</i> has identified an overheating condition. Check the water pump indicator for a steady stream of water. Shut OFF the engine. Clear the water intake screens of any debris. If the overheat condition still exists, the engine will operate in “get home” mode. Return to harbor immediately.• A flashing light — The <i>EMM</i> has identified a damaging overheating condition. The engine will not operate. Allow the engine to cool for 20 minutes and return to harbor immediately. See your Dealer.

“CHECK ENGINE” or “CHK ENG”

Symptom	An abnormal operating condition
Result	<i>EMM</i> will activate check engine light or display warning
Action	<ul style="list-style-type: none">• A flashing light — The <i>EMM</i> has identified an abnormal operating condition related to the fuel system. The engine will shut OFF and cannot be restarted.• A continuous light with <i>S.A.F.E.</i> mode — The <i>EMM</i> has identified a problem with the outboard. Seek assistance and/or return to harbor. See your Dealer.• A continuous light without <i>S.A.F.E.</i> mode — The <i>EMM</i> has identified a problem that should be addressed by your Dealer as soon as practical to avoid operational difficulties.

WARNING

If the outboard shuts OFF and the “CHECK ENGINE” or “CHK ENG” light is flashing, the outboard cannot be restarted. A hazardous fuel condition may exist. Seek assistance to return to port.

*Speed Adjusting Failsafe Electronics

ENGINE OVERHEATING

NOTICE Do not run your outboard—even for a brief start-up—without supplying water to it. Refer to **FLUSHING** on page 44.

While boating, the outboard's water intakes must stay completely submerged and unobstructed. Observe proper transom height and tilt angle. While the outboard is running, the outboard's water pump indicator must discharge a steady stream of water. Check the indicator often, especially when operating in weeds, muddy and debris-laden water, and at extreme trim angles.

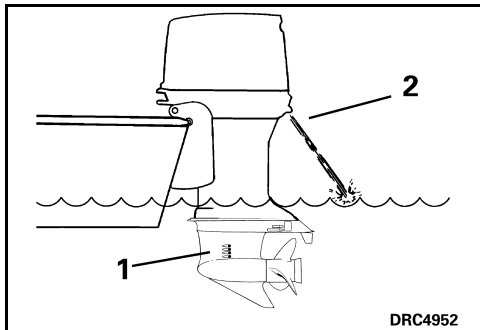

1. Water intake screens
2. Water pump indicator

If the engine overheats, the S.A.F.E. (Speed Adjusting Failsafe Electronics) mode will immediately limit the engine's speed to 1200 RPM. If the engine was running faster than 1200 RPM when the S.A.F.E. mode activated, it will shake noticeably. The protection system must be **RESET** before the engine will operate at speeds over 1200 RPM. Under certain conditions the *EMM* will shut off the engine.



To **RESET** the system:

- The engine must be shut off and the cooling temperature restored.

IF the S.A.F.E. mode activates and the stream from the water pump indicator becomes intermittent or stops, reduce speed to idle and:

- 1) Shift to NEUTRAL.
- 2) SHUT OFF the engine.
- 3) Tilt the outboard up.
- 4) Clean the intake screens of any blockage.
- 5) Clean the water pump indicator of any blockage.
- 6) Lower the outboard.
- 7) Restart the engine and run at idle.

IF cleaning the screens and indicator *does not* restore the water pump indicator's steady discharge, the engine will operate only in "get home" mode. Return to harbor immediately. See your Dealer.

IF cleaning the screens and indicator *does* restore the water pump indicator's steady discharge, you might have to run for two minutes in NEUTRAL to allow the engine to cool.

NOTICE If cooling is not restored, the *EMM* will identify a progressive overheating condition and shut off the engine. The engine will not restart until the engine is allowed to cool.

After any overheat causing engine shutdown, see your Dealer for:

- Inspection of the water pump for excessive wear or damage.
- Inspection of the thermostats.

NOTICE Although the S.A.F.E. mode can help prevent engine damage, it does not guarantee you can run your engine indefinitely without engine damage.

ROUTINE INSPECTION CHECKLIST

Pre-Launch Checks (Each Use)

- Check fuel level.
- Check oil level.
- Check function of steering, throttle, shift, and emergency stop circuit and lanyard.
- Check condition of propeller.
- Confirm operation of engine monitor system self-test and warning horn.
- Confirm the cooling system is operational (water intake screens and water pump indicator).
- Confirm this Operator's Guide is onboard and readily accessible.

Periodic Checks

- Check condition of anti-corrosion anodes (annually or every 100 hours).
- Check for debris on propeller shaft (requires propeller removal).
- Clean and wax upper and lower engine covers (annually or every 100 hours).
- In salt water applications, check lubrication points and corrosion protection. Use *Evinrude* anti-corrosion spray or *Evinrude* "6 in 1" multi-purpose lubricant (annually or 100 hours).

MAINTENANCE

ENGINE EMISSIONS INFORMATION

Maintenance, replacement, or repair of the emission control devices and systems may be performed by any marine SI (spark ignition) engine repair establishments or individual.

Manufacturer's Responsibility

Beginning with 1999 model year outboards, manufacturers of marine engines must determine the exhaust emission levels for each engine horsepower family and certify these outboards with the United States of America Environmental Protection Agency (EPA). An emissions control information label, showing emission levels and engine specifications, must be placed on each outboard at the time of manufacture.

Dealer's Responsibility

When performing service on all 1999 and more recent *Evinrude* outboards that carry an emissions control information label, adjustments must be kept within published factory specifications.

Replacement or repair of any emission related component must be executed in a manner that maintains emission levels within the prescribed certification standards.

Dealers are not to modify the outboard in any manner that would alter the horsepower or allow emission levels to exceed their predetermined factory specifications.

Exceptions include manufacturer's prescribed changes, such as altitude adjustments, for example.

Owner Responsibility

The owner/operator is required to have engine maintenance performed to maintain emission levels within prescribed certification standards.

The owner/operator is not to, and should not allow anyone to, modify the engine in any manner that would alter the horsepower or allow emissions levels to exceed their predetermined factory specifications.

Tampering with the fuel system to change horsepower or modify emission levels beyond factory settings or specifications will void the product warranty.

EPA Emission Regulations

All new 1999 and more recent *Evinrude* outboards manufactured by BRP are certified to the EPA as conforming to the requirements of the regulations for the control of air pollution from new watercraft marine spark ignition engines. This certification is contingent on certain adjustments being set to factory standards. For this reason, the factory procedure for servicing the product must be strictly followed and, whenever practicable, returned to the original intent of the design. The responsibilities listed above are general and in no way a complete listing of the rules and regulations pertaining to the EPA requirements on exhaust emissions for marine products. For more detailed information on this subject, you may contact the following locations:

VIA U.S. POSTAL SERVICE:

Office of Mobile Sources
Engine Programs and Compliance Division
Engine Compliance Programs
Group (6403J)
401 M St. NW
Washington, DC 20460

VIA EXPRESS or COURIER MAIL:

Office of Mobile Sources
Engine Programs and Compliance Division
Engine Compliance Programs
Group (6403J)
501 3rd St. NW
Washington, DC 20001

EPA INTERNET WEB SITE:

www.epa.gov

MAINTENANCE SCHEDULE

Routine inspection and maintenance is necessary to prolong outboard life. The following chart provides guidelines for inspection and maintenance to be performed by an authorized Dealer.

IMPORTANT: Outboards used in rental, commercial, or other high hour applications require more frequent inspections and maintenance. Adjust schedule for operating and environmental conditions.

Description	Engine Care Product	Every 300 Hours or Three Years ⁽¹⁾
Electrical and ignition wires, inspect for wear or chafing		✓
Engine to transom mounting hardware, re-torque (54 N•m (40 ft. lbs.))		✓
Fasteners, inspect any loosened components		✓
Fuel and oil system components, inspect and repair leaks ⁽²⁾		✓
Fuel filter, replace		✓
Gearcase lubricant, replace	A	✓
Grease fittings, lubricate ⁽³⁾	C	✓
Muffler foam, inspect and replace if necessary		✓
Power trim/tilt system and fluid level, inspect	B	✓
Propeller shaft splines, inspect and lubricate ⁽³⁾	C	✓
Spark plugs, inspect and replace if necessary ⁽²⁾		✓
Starter pinion shaft, inspect and lubricate	D	✓
Steering system, inspect and lubricate	C	✓
Thermostats, inspect ⁽²⁾		✓
Throttle cable, inspect and re-tension		✓
Water pump, inspect or replace if necessary		✓

- (1) Average recreational use. Commercial use, heavy use, or use in salt or polluted water requires more frequent inspection and maintenance (annual checks are recommended).
- (2) Emission-related component – Refer to **Owner Responsibility** on page 42, **PRODUCT WARRANTY INFORMATION** on page 58 and, if applicable, **CALIFORNIA EMISSION CONTROL WARRANTY STATEMENT** on page 61
- (3) Annually in salt water applications – Refer to **Salt Water Lubrication Points** on page 35

- A. *HPF XR* Gearcase Lubricant
HPF Pro Gearcase Lubricant in high performance or commercial applications
- B. *Evinrude/Johnson* Biodegradeable TNT Fluid
- C. *Triple-Guard* Grease
- D. Starter Bendix Lube ONLY, P/N 337016

SERVICE TIPS

FLUSHING

If desired, the outboard can be flushed after each use on a trailer or at dockside while it is vertical.

- 1) Place the outboard in an area with good drainage.
- 2) Connect garden hose to flushing port.
- 3) Turn on the water. It is **not** necessary to run the engine for a good flushing.

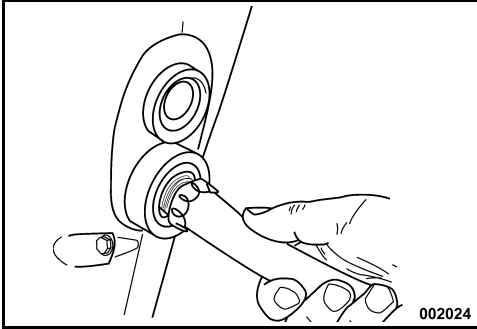

- 4) Leave the outboard in vertical position long enough to completely drain the powerhead.

NOTICE If you cannot store the outboard in the recommended vertical position, be sure the cooling system is drained completely. Never place the gearcase higher than the powerhead. Any water remaining in the exhaust passages can run into the cylinders and cause serious damage.

SUBMERGED OUTBOARD

If your outboard has been under water, **have it serviced immediately upon recovery**. If immediate service is unavailable, resubmerge it in fresh water to avoid prolonged exposure to the atmosphere.

After submersion, all boat and engine electrical, fuel, and oiling systems must be inspected for signs of water intrusion. Your Dealer should perform this service.

OUTBOARD EXTERNAL FINISH



Your outboard's upper and lower engine covers use mold-in color technology, providing a deep, durable gloss with maximum ultraviolet (sunlight) protection.

The high gloss finish will show polish marks when viewed closely in certain light conditions. This glossing is **NORMAL**.

Periodically, wash the entire boat and outboard with soapy water and apply a coat of automotive wax. Leave the engine cover in place when washing the outboard.

NOTICE When trailering your outboard, **DO NOT** cover the engine with canvas—it will dull the finish of the outboard's engine covers.

IMPORTANT:

SCRATCH REPAIR



Surface scratches on the upper and lower engine covers can be polished out with buffing compound.

Treat affected areas using these steps:

- 1) Sand the affected area with 800-grit sandpaper.
- 2) Wet sand the area with 1200-grit sandpaper.
- 3) Using a composite material buffing compound, polish the area, closely following the product directions.

NOTICE Your Dealer has the professional materials to properly repair scratches. Do not attempt to paint over marks or scratches in the composite material. See your Dealer to repair any deep scratches or gouges.

HULL FINISH

The condition of your boat's bottom affects performance. Marine growth or bottom painting may reduce speed and fuel efficiency.

For maximum performance, keep the boat's running surface clean by rinsing it with fresh water and wiping it dry. Apply *Evinrude* anti-corrosion spray to any surface subject to corrosion, but avoid the anti-corrosion anode(s).

SPARK PLUGS

⚠ CAUTION

The ignition system presents a serious shock hazard. Use caution to avoid injury from shock or injury resulting from your reaction to shock. Do not handle primary or secondary ignition components while the engine is cranking or running.

Spark plugs should be serviced by an *Evinrude E-TEC* Dealer. Incorrect spark plug maintenance can lead to engine damage.

NOTICE Replacement spark plugs MUST be indexed correctly.

Marine Engine Duty Cycles

The International Council of Marine Industry Associations (ICOMIA) Standard No. 36-88 specifies a marine engine duty cycle based on documented studies. A duty cycle is a profile of engine running and usage. This duty cycle is used to determine average spark plug longevity and maintenance requirements for *Evinrude E-TEC* outboards.

ICOMIA Marine Engine Duty Cycle	
Engine Speed as Percentage of Rated Speed (RPM)	Time at Specified RPM (Percentage of total engine running time)
IDLE	40%
40%	25%
60%	15%
80%	14%
100%	6%

NOTICE Some running profiles and conditions can lead to spark plug wear sooner than expected. Depending on your specific usage, the spark plug maintenance schedule may require adjustment.

FUSE



A blown fuse will not allow the engine to crank. Replace it with a fuse of the same rating. A spare fuse is provided.

Repeated fuse failures indicate a potentially serious problem. Do not replace it with higher rated fuse; see your Dealer for service.

Fuse Replacement

NOTICE Use only fuses of the same rating. Your *Evinrude E-TEC* outboard uses 10-amp fuses.

Remove engine cover. Install spare fuse in place of failed fuse.

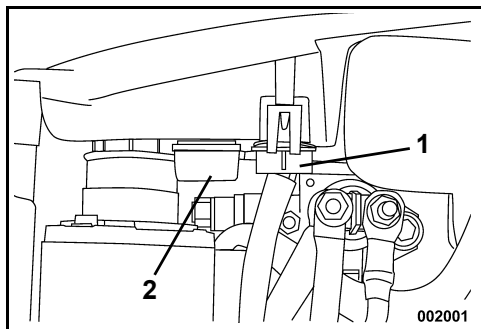

1. Fuse
2. Spare fuse

NOTICE Failure to install cover securely may cause electrical problems.

TRANSPORTING / STORAGE



If the outboard is laid down for transportation or storage, the oiling system must be primed before reusing the outboard. Refer to **Priming the Oil System** on page 17.

STORAGE

LONG-TERM STORAGE (WINTERIZATION)

DANGER

DO NOT run the engine indoors or without adequate ventilation or permit exhaust fumes to accumulate in confined areas. Engine exhaust contains carbon monoxide which, if inhaled, can cause serious brain damage or death.

You must protect against natural environmental conditions that can be damaging to an outboard. Your warranty does not cover engine failure caused by these conditions.

NOTICE Temperature and humidity changes during storage period can cause corrosion of internal engine components.

Winterization prepares your outboard for long-term off-season storage. During winterization, the engine is “fogged” and extra oil is used to coat internal engine components. Refer to **LONG-TERM STORAGE (WINTERIZATION)** on page 46.

Stabilize the fuel supply. Fuel remaining in your fuel tank can oxidize, resulting in loss of octane and fuel system deposits.

Use *Evinrude/Johnson 2+4 Fuel Conditioner* to prevent gum and varnish deposits from forming in fuel system components. Refer to **OPERATION** on page 19.

WARNING

Prevent injury from moving engine components. Before starting the outboard:

- Shift it to **NEUTRAL**.
- Keep hands, clothes, and hair clear of powerhead.
- Remove the propeller.

Store fuel tanks in a well-ventilated area, away from heat and open flame. Prevent escape of liquid or vapors which could accidentally ignite. Close filler cap vent screws (if equipped) and be sure any disconnected fuel hoses do not drip.

WARNING

Outboard must be in NEUTRAL before performing winterization. Starting outboard in gear can cause personal injury.

If winterizing on a trailer, the propeller must be removed before performing procedure. Failure to remove propeller can cause personal injury or death.

Winterization prepares your outboard for long-term off-season storage. During winterization, the engine is “fogged” and extra oil is used to coat internal engine components.

Winterization requires a specific process of steps.

Closely follow the applicable winterization procedure for your outboard:

- Remote control
- Tiller control
- Remote control with foot throttle

If you are unsure which procedure is right for you, contact your Dealer for assistance.

You can confirm your outboard enters winterization mode when the engine runs at fast idle and:

- The *SystemCheck* gauge lights flash (if equipped).
- The *I-Command* gauge displays winterization message (if equipped).

SHORT-TERM STORAGE

If you must tilt the outboard to remove it from the water, lower it and allow the cooling system to drain completely as soon as you clear the launch area.

Between uses, store your outboard in a vertical position.

Preparation – All Outboards

Your outboard can be winterized in the water. **If winterizing in water**, make sure the water intake screens are completely submerged.

- 1) Stabilize the engine's fuel supply. Add 2+4 Fuel Conditioner following instructions on container. Fill fuel tank.
- 2) **If winterizing on a trailer**, remove the propeller. Attach a garden hose to flushing port and turn on the water. Refer to **SHORT-TERM STORAGE** on page 46.
- 3) Outboard **must** be in NEUTRAL, and remote control and shift linkage must be in NEUTRAL position at all times during winterization procedure.

Remote Control Outboards

- 1) **For side mount controls**, lift fast idle lever. Start the outboard. Outboard runs at slow idle speed.

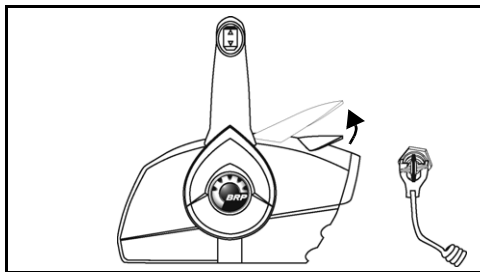

Side Mount Control – Typical

For binnacle or concealed side mount controls, press fast idle button and advance throttle handle to HALF throttle position. Start the outboard. Outboard runs at slow idle speed.

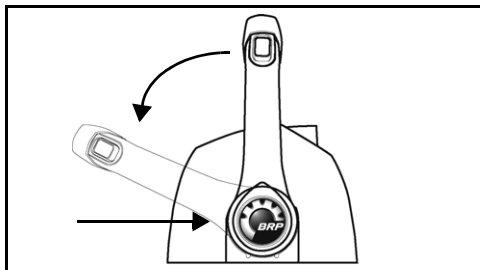

Binnacle Control – Typical

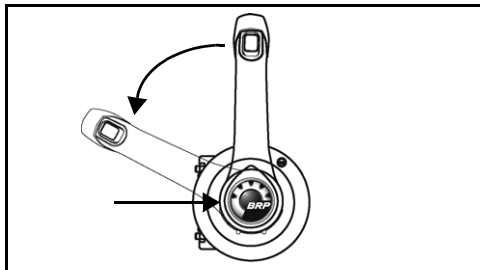

Concealed Side Mount Control – Typical

- 2) After outboard runs for about 15 seconds:

For side mount controls, lower fast idle lever.

For binnacle or concealed side mount controls, return throttle handle to IDLE position.

Outboard continues to run at slow idle speed.

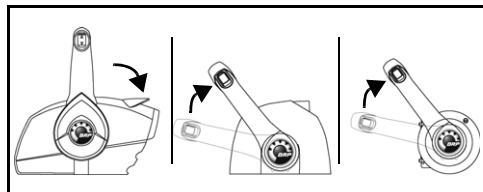

- 3) After outboard runs for another 15 seconds:

For side mount controls, raise fast idle lever again.

For binnacle or concealed side mount controls, advance throttle handle to HALF THROTTLE position.

Outboard will accelerate to fast idle speed and fog itself.

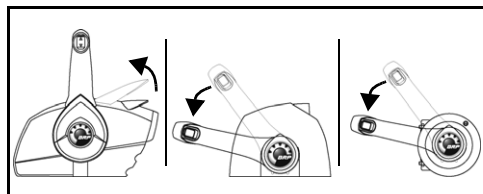

- 4) Allow outboard to run until it shuts itself OFF automatically (less than one minute).

► MAINTENANCE

Winterization is complete when outboard shuts itself off.

- **If the outboard DOES NOT shut itself off**, you may not have used the fast idle lever or button and the outboard was shifted into gear.
- **If the engine exceeds 3000 RPM**, the outboard may have been shifted into gear.

In either event, immediately turn key switch OFF and re-start the procedure.

Tiller Control Outboards

- 1) Advance throttle grip to HALF THROTTLE position. Start the outboard. Outboard runs at slow idle speed.

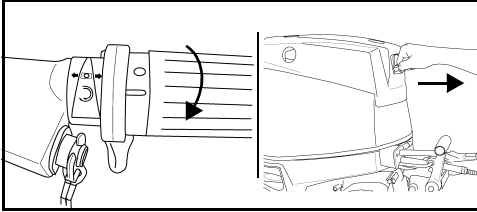

Tiller Control – Typical

- 2) After outboard runs for about 15 seconds, move throttle grip to IDLE position. Outboard continues to run at slow idle speed.

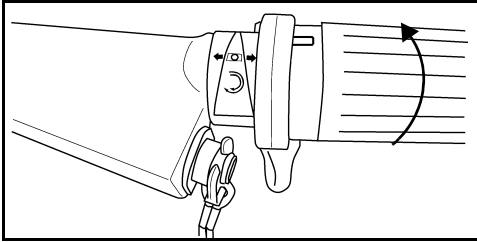

- 3) After outboard runs for another 15 seconds, advance throttle grip to HALF THROTTLE position. Outboard will accelerate to fast idle speed and fog itself.
- 4) Allow outboard to run until it shuts itself OFF automatically (less than one minute).

Winterization is complete when outboard shuts itself off.

- **If the outboard DOES NOT shut itself off**, you may not have properly advanced throttle grip.
- **If the engine exceeds 3000 RPM**, the outboard may have been shifted into gear.

In either event, immediately press STOP button to turn outboard OFF and re-start the procedure.

Remote Control Outboards with Foot Throttle

- 1) Press foot throttle to HALF THROTTLE position. Start the outboard. Outboard runs at slow idle speed.

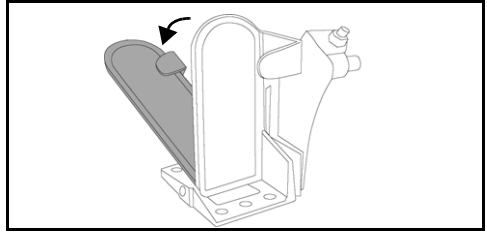

Foot Throttle – Typical

- 2) After outboard runs for about 15 seconds, remove foot from foot throttle and allow throttle to return to IDLE position. Outboard continues to run at slow idle speed.

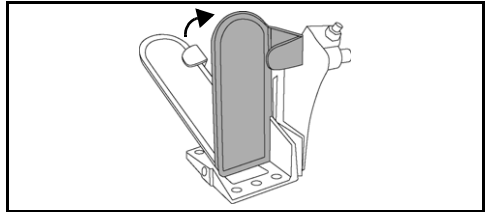

- 3) After outboard runs for another 15 seconds, press foot throttle to HALF THROTTLE position. Outboard will accelerate to fast idle speed and fog itself.

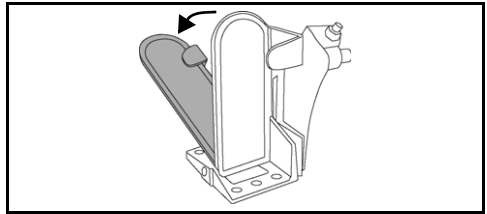

- 4) Allow outboard to run until it shuts itself OFF automatically (less than one minute).

Winterization is complete when outboard shuts itself off.

- If the outboard DOES NOT shut itself off, you may not have allowed enough running time at a throttle position.
- If the engine exceeds 3000 RPM, the outboard may have been shifted into gear.

In either event, immediately turn key switch OFF and restart the procedure.

After Winterization – All Outboards

- 1) After the outboard shuts itself off, turn key switch OFF. (For tiller models, remove emergency stop clip / key switch.) Do not start the outboard again after winterization is completed.
- 2) If winterizing on a trailer, turn off water and detach garden hose. Grease propeller shaft splines with recommended lubricant, and re-install propeller.

IMPORTANT: When winterizing is finished, leave the outboard in vertical position long enough to completely drain the powerhead. If equipped, disconnect the speedometer pickup at the upper connection and blow all water out of the hose using air pressure of 25 psi or less. Reconnect speedometer pickup after all the water has been removed.

- 3) Top off oil tank.



Extra engine oil is used during the winterization procedure. Some excess oil may appear on the skeg below the gearcase area. **This is normal.**

Avoid potential oil stains by placing a shop towel or suitable container under the propeller and skeg for the duration of the storage.

PRE-SEASON CHECK

Prepare your outboard for a season of reliable service by performing a general check and a few preventive maintenance procedures.

Examine all loosened or removed hardware. Replace damaged or missing parts with *Evinrude/Johnson Genuine Parts* or equivalent. Check the gearcase for leakage. If leakage is evident, the gearcase seals should be replaced. See your Dealer.

IMPORTANT: Gearcase lubricant is **thick and clear**. Do not confuse this with engine oil, which may normally appear on the skeg after performing the long-term (winterization) storage procedure.

Anticorrosion anodes — Check condition. Refer to **Anti-Corrosion Anodes** on page 35.

Battery — Charge fully. Refer to **BATTERY** on page 53.

Review your outboard’s warning system self-test routine. During your preseason start-up, make sure the warning system self-tests properly. If it does not, see your Dealer.

IMPORTANT: Do not run your outboard—even for a brief start-up—without supplying water to it. Refer to **SHORT-TERM STORAGE** on page 46.

Following **ENGINE STARTING** on page 19, start the outboard. If the outboard was auto-winterized, it will smoke for a short time after the first start of the season.

Let engine idle and observe running quality. If poor, refer to **TROUBLESHOOTING** on page 50 or see your Dealer.

Let engine idle and confirm water pump operation. Water must flow from the water pump indicator in a steady stream. If it does not, shut off the outboard and investigate. Refer to **ENGINE OVERHEATING** on page 39.

Stop the outboard and check the fuel system for leaks.

⚠ WARNING

Failure to check for fuel leakage could allow a leak to go undetected, resulting in fire or explosion.

⚠ WARNING

Do not use a booster battery and jumper cables to start the outboard. Gasoline fumes can cause explosion and fire, resulting in property damage, personal injury or death.

TROUBLESHOOTING

SYMPTOM	POSSIBLE CAUSE
Starter motor will not operate	<ul style="list-style-type: none"> • Shift handle not in NEUTRAL. • Fuse blown. • Battery is dead.
Engine will not start	<ul style="list-style-type: none"> • Not following starting instructions. Refer to ENGINE STARTING on page 19. • Fuel tank empty. • Fuel hose kinked. • Fuel system contaminated with water or dirt. • Fuel filter obstructed. • Throttle not at IDLE. Return throttle to IDLE. • Spark plugs incorrect. Refer to SPARK PLUGS on page 45. • Spark plugs improperly gapped, carboned, burned, or wet. • Fuse blown. • Flashing “Water Temp” or hot light, refer to ENGINE MONITOR WARNINGS on page 37 and ENGINE OVERHEATING on page 39. • Flashing “Check Engine” or “Chk Eng” light, refer to ENGINE MONITOR WARNINGS on page 37.
Engine will not idle properly	<ul style="list-style-type: none"> • Debris on propeller. • Spark plugs damaged or incorrect. Refer to SPECIFICATIONS on page 57. • Fuel system contaminated with water or dirt.
Engine loses power	<ul style="list-style-type: none"> • Spark plugs damaged or incorrect. Refer to SPARK PLUGS on page 45. • Fuel filter obstructed. • Fuel system contaminated with water or dirt. • Water intakes obstructed and cooling system not operating correctly. Refer to ENGINE OVERHEATING on page 39. • Oiling system malfunction. • S.A.F.E. protection mode activated. Refer to ENGINE MONITOR WARNINGS on page 37.
Engine runs, but makes little or no progress	<ul style="list-style-type: none"> • Propeller hub loose, slipping. • Propeller blades bent or missing. • Propeller shaft bent. • Propeller debris.
Warning system activates	<ul style="list-style-type: none"> • Refer to ENGINE MONITOR WARNINGS on page 37.

PRODUCT INFORMATION

RIGGING AND ACCESSORIES

PROPELLER

Propeller Selection

⚠ WARNING

Be alert of people in the water. Always shift the outboard to **NEUTRAL** and shut off the engine immediately when your boat is in an area where there might be people in the water. Serious injury or death can result from contacting a rotating propeller or moving boat and outboard.

To select the correct propeller for your boating application, your boat and outboard **MUST** be water tested. See your Dealer for assistance.

IMPORTANT: The correct propeller for your boat, under normal load conditions, will allow the engine to run near the midpoint of the RPM operating range at full throttle. Refer to **SPECIFICATIONS** on page 57.

⚠ WARNING

When servicing the propeller, always shift the outboard to **NEUTRAL** position, turn the key switch **OFF**, and twist and remove all spark plug wires so the outboard cannot be started accidentally.

Standard vs. Counter Rotation

Right-hand propellers are considered standard rotation propellers. When propelling a boat forward, the propeller rotates in a right-hand (clockwise) direction as viewed from the rear.

Left-hand propellers are considered counter rotation propellers. When propelling a boat forward, the propeller rotates in a left-hand (counterclockwise) direction as viewed from the rear.

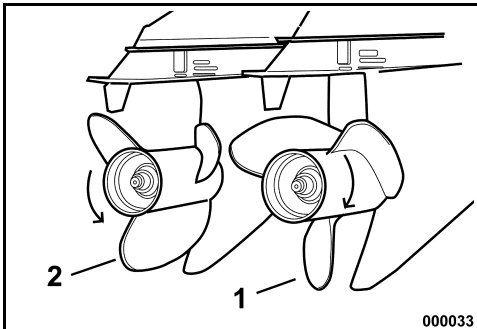

000033

1. Right-Hand (clockwise)
2. Left-Hand (counterclockwise)

⚠ WARNING

In dual-outboard installations, check to make sure correct propellers are installed on each outboard before aggressively operating your boat. Shift each engine individually into **FORWARD** or **REVERSE**, at idle speed only. If the boat moves opposite the direction indicated by the remote control handle, the wrong propeller has been installed on the outboard being checked.

Installation

NOTICE Apply *Triple-Guard* grease to the entire propeller shaft before installing the propeller. At least annually, remove the propeller and check for debris. Clean the shaft and regrease it before reinstalling a propeller.

Slide thrust washer onto shaft with shoulder facing aft.

Slide propeller onto shaft, engaging the splines and seating it on the thrust bushing.

Slide spacer onto the shaft and engage the propeller shaft splines.

Wedge a block of wood between the propeller blade and the anti-ventilation plate.

Install propeller nut and tighten to a torque of 13.6-16.3 N·m (120-144 in. lbs.).

Install keeper on propeller nut, align keeper slots and cotter pin hole.

Install new cotter pin and bend ends to secure.

Remove block of wood. Make sure engine is in NEUTRAL; give propeller a spin. It must turn freely.

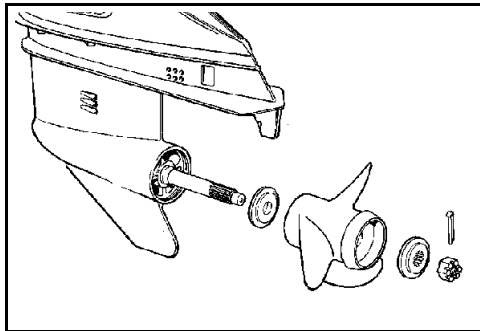

Repair

If your propeller hits a solid object, the impact is partially absorbed by the rubber bushing in the hub to help prevent damage to the outboard. A strong impact can damage the hub and propeller blades. Damage to blades can cause unusual and excessive vibration. Damage to the hub can cause excessive engine RPM with little forward movement.

NOTICE Avoid or limit operation using a damaged propeller. Carry a spare propeller.

Keep your propeller in good condition. Use a file to smooth slight damage to blade edges. See your Dealer for repair of serious damage.

BATTERY

Requirements

- 12-volt, heavy-duty, designated for "marine" use;
- Vented/refillable or maintenance-free; and
- Rated according to the minimum requirements in **SPECIFICATIONS** on page 57.

Deep-cycle batteries are suitable **IF** they meet or exceed the minimum CCA requirements.

Ask your Dealer about your outboard's requirements before installing longer battery cables or a battery switch.

Installation

⚠ WARNING
 Read and understand the safety information supplied with your battery **BEFORE** you begin installation.

NOTICE Make sure all components are clean and free of corrosion. Connect the RED (+) cable to the positive (+) battery post first. Connect the BLACK (-) cable to the negative (-) battery post last.

Connect the RED (+) cable to the positive (+) battery post first. Connect the BLACK (-) cable to the negative (-) battery post last.

If you have marine battery posts, install each main cable on the clamp adapter with a starwasher below it. Install all wires from accessories on the threaded portion of the post.

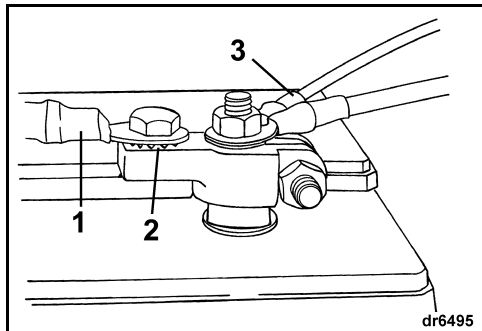

1. Main cable
2. Starwasher
3. Accessory wires

If you have automotive battery posts, place a starwasher on the clamp adapter first, then the main cable, and then the wires from the accessories.

► PRODUCT INFORMATION

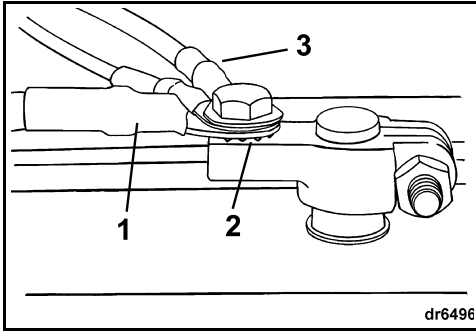

1. Main cable
2. Starwasher
3. Accessory wires

Tighten all connections securely and coat the installation with *Triple-Guard* grease.

⚠ WARNING

Keep the battery connections clean, tight, and insulated to prevent their shorting or arcing and causing an explosion. If the battery mounting system does not cover the connections, install covers. Check often to see that connections stay clean and tight.

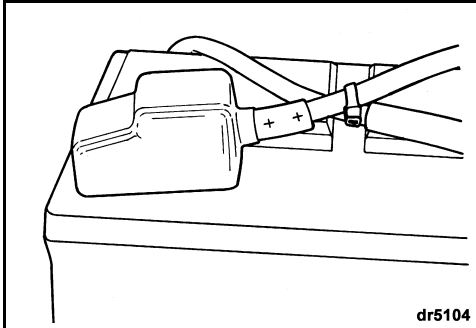

NOTICE DO NOT use wing nuts on battery connections even if they came with the battery. Wing nuts can loosen and cause errant warning signals or electrical system damage.

Service

Before servicing the battery or the outboard, remove both battery cables from the battery, battery negative (-) cable first. Keep metal objects from contacting either battery post.

NOTICE Service electrical components only while the outboard is NOT running. Be careful when identifying positive and negative battery cables and posts.

⚠ WARNING

Battery electrolyte is acidic — handle with care. If electrolyte contacts any part of the body, immediately flush with water and seek medical attention.

Do not use a booster battery and jumper cables to start the outboard. Gasoline fumes can cause explosion and fire, resulting in property damage, personal injury or death.

WATER PRESSURE

An optional water pressure gauge is recommended to monitor cooling system pressures. Noticing changes in water pressure can help prevent engine overheating. The water pressure gauge must be connected at the correct point to ensure the most accurate pressure readings. Follow the installation instructions included with the water pressure gauge.

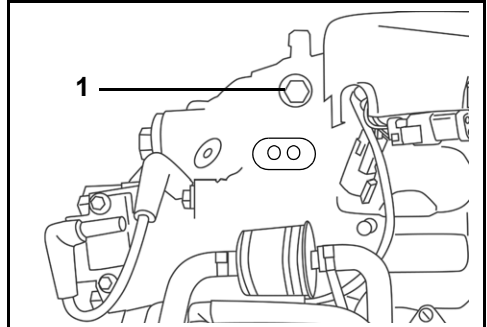

1. Water pressure port (starboard side)

ADJUSTMENTS

Idle RPM in Gear

The idle RPM in gear setting can be adjusted, if desired, to provide more idle control, steering, and quietness in certain applications.

IMPORTANT: Only your Dealer can adjust the idle RPM in gear setting.

Trim Tab

WARNING

Improper trim tab adjustment can cause difficult steering.

A propeller will generate steering torque when the propeller shaft is not running parallel to the water's surface. The trim tab is adjustable to compensate for this steering torque.

IMPORTANT: A single trim tab adjustment will relieve steering effort under only one set of speed, outboard angle and load conditions. No single adjustment can relieve steering effort under all speed, outboard angle and load conditions. If the boat pulls to the left or right when its load is evenly distributed, adjust the trim tab as follows:

With the outboard shut OFF, loosen the trim tab screw. If the boat pulled to the right, move the rear of the trim tab slightly to the right. If the boat pulled to the left, move the rear of the trim tab slightly to the left.

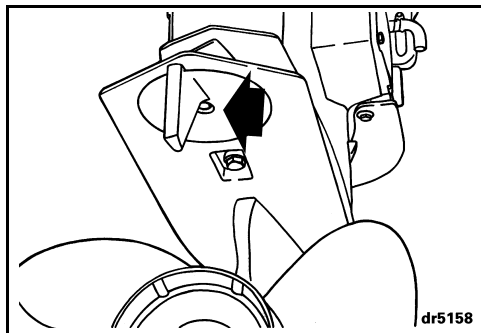

Tighten the trim tab screw to a torque of 47-54 N·m (35-40 ft. lbs.).

Test the boat and, if needed, repeat the procedure until steering effort is as equal as possible.

High outboard installations — The trim tab might be above the water when the outboard is trimmed out. Steering effort might increase. Steering effort will be reduced if you trim the outboard in and submerge the trim tab.

Dual standard rotation outboards — Move both trim tabs equally and in the same direction.

Dual outboards (one counter and one standard rotation) — Set both trim tabs to the center position.

► PRODUCT INFORMATION

Tilt Limiter Cam

If your outboard contacts the boat's motor well while tilting, adjust the tilt limiter cam to limit maximum tilt-up.

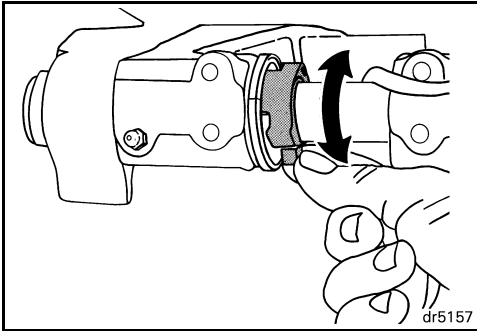

Place the outboard in its normal operating position.

Rotate the tilt limiter cam — pull its tab forward and up to **REDUCE** the amount of tilt UP.

Check your adjustment — tilt the outboard fully and adjust further, if necessary. Return the outboard to vertical position for each adjustment, and repeat your check after each adjustment.

⚠ WARNING

Adjusting the tilt limiter cam will **NOT** prevent the outboard from tilting fully and contacting the motor well if the gearcase hits an object at high speed. Such contact could damage the outboard and boat and injure boat occupants.

SPECIFICATIONS

75, 90 Models	
Displacement	1296 cc (79.1 cu. in.)
Engine Type	In-line, 3 Cylinder, Two-Cycle, <i>E-TEC</i>
Full Throttle Operating Range	75 HP – 4500 to 5500 RPM 90 HP – 4500 to 5500 RPM
Power ⁽¹⁾	75 HP – 75 HP (56 kw) @ 5000 RPM 90 HP – 90 HP (67.1 kw) @ 5000 RPM
Idle RPM in Gear ⁽²⁾	700 ± 50
Idle RPM in Neutral ⁽²⁾	600 ± 50
Ignition Timing ⁽²⁾	Not Adjustable
Emission Control System: per SAE J1930 ⁽²⁾	ECM, <i>E-TEC</i> (Engine Control Module, <i>E-TEC</i>)
Fuel Requirements ⁽²⁾	87 Pump Posted AKI (90 RON) – Refer to Minimum Octane on page 17
Oil – Lubricant – Capacity	TC-W3 NMMA-certified oil or <i>Evinrude/Johnson XD100</i> oil – Refer to OIL REQUIREMENTS on page 16 2.8 l (3.0 qt.)
Warning Signals	Controlled by the outboard's <i>EMM</i>
Battery, Minimum ⁽³⁾	800 MCA (640 CCA) 12 volt or 1000 MCA (800 CCA) 12 volt below 0°C (32°F)
Spark Plug ⁽²⁾	Refer to ECI Label
Fuses	Refer to FUSE on page 45
Fuel Filter	In-line Replaceable
Battery Charging	25-Amp, Fully Regulated
Gearcase – Lubricant ⁽⁴⁾ – Capacity	<i>Evinrude Ultra-HPF</i> L Models – 935 ml (31.6 fl. oz.) X Models – 970 ml (32.8 fl. oz.)
Power Trim/Tilt – Fluid Capacity	622 ml (21 fl. oz.)
Propeller	Refer to Propeller Selection on page 52
Weight	L Models – 145 kg (320 lbs.) X Models – 152 kg (335 lbs.)
Sound at Driver's Ear (LpA) ICOMIA 39.94	76.8 dB(A)
Transom Height	L Models – 495 to 508 mm (19 1/2 to 20 in.) X Models – 622 to 635 mm (24 1/2 to 25 in.)

(1) Rated following the standards of ICOMIA 28.83, ISO 3046 and NMMA.

(2) Emission Control Information.

(3) Use a 1000 MCA (800 CCA) battery when operating in temperatures below 0°C (32°F).

(4) Use *Evinrude/Johnson HPF Pro* Gearcase Lubricant for high performance outboards and commercial applications. *Evinrude/Johnson HPF Pro* Gearcase Lubricant delivers exceptional durability and reliability and promotes long gearcase life in marine use.

PRODUCT WARRANTY INFORMATION

BOMBARDIER RECREATIONAL PRODUCTS LIMITED WARRANTY FOR 2010 EVINRUDE OUTBOARD ENGINES SOLD IN THE UNITED STATES AND CANADA

1. SCOPE OF THE LIMITED WARRANTY

Bombardier Recreational Products* ("BRP") warrants its 2010 *Evinrude*® outboard engines sold by authorized *Evinrude* dealers in the fifty United States and Canada ("Product") from defects in material or workmanship for the period and under the conditions described below.

2. EXCLUSIONS — The following are not warranted under any circumstances:

- Replacement of parts due to normal wear and tear;
- Routine maintenance parts and services including but not limited to: maintenance requirements, engine and lower unit oil changes, lubrication, valve and linkage adjustments and replacement of fuses, zinc anodes, thermostats, timing belts, starter motor bushings, trim motor brushes, filters, propellers, propeller bushings and spark plugs;
- Damage caused by improper or lack of installation, maintenance, winterization and/or storage, failure to follow the procedures and recommendations in the Operator's Guide;
- Damage resulting from removal of parts, improper repairs, service, maintenance, or modification, or use of parts or accessories not manufactured or approved by BRP, which in its reasonable judgment, are either incompatible with Product or adversely affect its operation, performance, or durability, or resulting from repairs done by a person that is not an authorized Dealer;
- Damage caused by abuse, misuse, abnormal use, neglect, racing, improper operation or operation of the Product in a manner inconsistent with the recommended operation described in the Operator's Guide;
- Damage resulting from external damage, accident, submersion, water ingestion, fire, theft, vandalism or any act of God;
- Operation without proper fuel, oil or lubrication, or with fuels, oils or lubricants which are not suitable for use with the Product (see the Operator's Guide);
- Damage resulting from rust or corrosion;
- Damage caused from cooling system blockage by foreign material;
- Damage resulting from sand or debris in the water pump;
- Cosmetic or paint changes due to exposure to the elements.

This warranty will be **voided in its entirety and rendered null and void** where:

- Product has been altered or modified in such a way so as to adversely affect its operation, performance or durability, or change its intended use, horsepower or emission levels; or
- Product is or has been used for racing at any point, even by a prior owner.

3. LIMITATIONS OF LIABILITY

ALL WARRANTIES, EXPRESSED OR IMPLIED, INCLUDING WITHOUT LIMITATION ANY WARRANTY OF MERCHANTABILITY OR FITNESS FOR A PARTICULAR PURPOSE ARE LIMITED IN DURATION TO THE LIFE OF THE EXPRESS LIMITED WARRANTY.

ALL INCIDENTAL, CONSEQUENTIAL, DIRECT, INDIRECT OR OTHER DAMAGES OF ANY KIND ARE EXCLUDED FROM COVERAGE UNDER THIS WARRANTY INCLUDING, BUT NOT LIMITED TO: expense for gasoline, expense for transporting Product to and from Dealer, removal of Product from a boat and reinstallation, mechanic's travel time, in-and-out of water charges, slip or dock fees, trailering or towing, storage, telephone, cell phone, fax or telegram charges, rental of a like or replacement Product or boat during warranty services or down time, taxi, travel, lodging, loss of or damage to personal property, inconvenience, cost of insurance coverage, loan payments, loss of time, loss of income, revenue or profits, or loss of enjoyment or use of Product.

SOME STATES, PROVINCES, OR JURISDICTIONS DO NOT ALLOW FOR THE DISCLAIMERS, LIMITATIONS OF INCIDENTAL OR CONSEQUENTIAL DAMAGES, OR OTHER EXCLUSIONS IDENTIFIED ABOVE. AS A RESULT, THEY MAY NOT APPLY TO YOU. THIS WARRANTY GIVES YOU SPECIFIC RIGHTS, AND YOU MAY ALSO HAVE OTHER LEGAL RIGHTS WHICH MAY VARY FROM STATE TO STATE, OR PROVINCE TO PROVINCE.

No distributor, Dealer or any other person is authorized to make any affirmation, representation or warranty regarding Product other than those contained in this limited warranty and, if made, shall not be enforceable against BRP. BRP reserves the right to modify this warranty at any time, being understood that such modification will not alter the warranty conditions applicable to the Products sold while this warranty is in effect.

4. WARRANTY COVERAGE PERIOD

This limited warranty will be in effect from the date of delivery to the first retail consumer or the date the Product is first put to use, whichever occurs first, for a period of:

THIRTY-SIX (36) CONSECUTIVE MONTHS for private, recreational use; or

TWELVE (12) CONSECUTIVE MONTHS for commercial use, except that emission-related components providing input to emission controls (e.g. sensors) are warranted for twenty-four (24) months or two hundred (200) hours of engine use, whichever occurs first. The Product is used commercially when it is used in connection with any work or employment that generates income, during any part of the warranty period. The Product is also used commercially when, at any point during the warranty period, it is installed on a boat that has commercial tags or is licensed for commercial use.

In cases where the delivery date is not established to BRP's satisfaction, the date of sale will be used to determine the warranty start date.

The repair or replacement of parts or the performance of service to Product under this warranty does not extend the life of this limited warranty beyond its original expiration date. All *Evinrude/Johnson® Genuine Parts* and accessories installed by an authorized dealer at the time of sale, including but not limited to propellers, bear the standard BRP parts and accessories one-year limited warranty.

California residents who purchased or warranty-registered a Product in California should refer to BRP's California Emissions Control Warranty Statement.

5. CONDITIONS TO HAVE WARRANTY COVERAGE

This warranty coverage is available only on *Evinrude* outboard engines purchased as new and unused from a dealer authorized to distribute *Evinrude* products in the country in which the sale occurred ("Dealer"), and then only after the BRP specified pre-delivery inspection process has been completed and documented by the purchaser and Dealer. Warranty coverage only becomes available upon proper registration of Product by Dealer or owner.

Only the original purchaser and any subsequent owners who reside in the United States and Canada and have purchased Product from a U.S. or Canadian Dealer are eligible for warranty registration and warranty coverage hereunder. Such limitations are necessary in order to allow BRP to protect the safety of its products, its consumers, and the general public.

As outlined in the Operator's Guide, timely routine required maintenance must be performed to maintain warranty coverage. BRP may require proof of proper maintenance prior to authorizing warranty coverage.

6. WHAT TO DO TO OBTAIN WARRANTY COVERAGE

The registered owner must notify an authorized Dealer within two (2) days of the appearance of a defect. Owner must bring Product, including any defective part therein, to Dealer promptly after the appearance of the defect, and in any event, within the warranty period, and must provide Dealer with reasonable opportunity to repair the defect. The expenses of transporting Product to and from Dealer for warranty service are to be borne by the owner.

If the Product has not previously been registered, the owner may also be required to present proof of purchase to Dealer for warranty repairs. Owner is required to sign the repair/work order prior to the start of the repair in order to validate the warranty repair.

All parts replaced under this warranty become the property of BRP.

7. WHAT BRP WILL DO

BRP's obligations under this warranty are limited to, at its sole discretion, repairing or replacing parts of Product found to be defective in material or workmanship, in the reasonable judgment of BRP. Such repair or replacement of parts will be done without charge for parts and labor, at any authorized Dealer. BRP's responsibility is limited to making the required repairs or replacements of parts with new or BRP-certified re-manufactured parts. No claim of breach of warranty shall be cause for cancellation or rescission of the sale of Product to owner.

In the event that warranty service is required outside of the fifty United States or Canada, owner will bear responsibility for any additional charges due to local practices and conditions, such as, but not limited to, freight, insurance, taxes, license fees, import duties, and any and all other financial charges, including those levied by governments, states, territories and their respective agencies.

BRP reserves the right to improve, modify or change Products from time to time without assuming any obligation to modify Products previously manufactured.

► **PRODUCT INFORMATION**

8. TRANSFER

If the ownership of Product is transferred during the warranty coverage period, this warranty shall also be transferred and be valid for the remaining coverage period provided that the former or new owner promptly contacts BRP or Dealer and gives the name and address of the new owner.

9. CONSUMER ASSISTANCE

- In the event of a controversy or dispute in connection with this BRP limited warranty, BRP recommends that you first try to resolve the issue at the dealership level by discussing the issue with Dealer's service manager or owner;
- If further assistance is required, please contact BRP US Inc. / Outboard Engines Division, After Sales Support, P.O. Box 597, Sturtevant, WI 53177, 1-847-689-7090.

BOMBARDIER RECREATIONAL PRODUCTS LIMITED WARRANTY FOR 2010 EVINRUDE OUTBOARD ENGINES SOLD OUTSIDE THE UNITED STATES AND CANADA

For a copy of the Limited Warranty, see your Bombardier Recreational Products ("BRP") distributor/dealer authorized to distribute *Evinrude* products in the country in which the sale occurs.

If further assistance is required, please contact BRP US Inc. / Outboard Engines Division, After Sales Support, P.O. Box 597, Sturtevant, WI 53177, or the affiliate of BRP where the Product was registered for warranty.

* Engines sold in Canada are distributed and serviced by Bombardier Recreational Products Inc.

Limited Warranty Revision US/CA February 2009

CALIFORNIA EMISSION CONTROL WARRANTY STATEMENT

Your *Evinrude E-TEC* outboard has a special environmental label required by the California Air Resources Board. The label has one, two, three, or four stars. A hangtag, provided with your outboard, describes the meaning of the star rating system.

The Star Label Means Cleaner Marine Engines



The Symbol for Cleaner Marine Engines:

Cleaner Air and Water

For a healthier lifestyle and environment.

Better Fuel Economy

Burns up to 30 to 40 percent less gas and oil than conventional carbureted two-stroke engines, saving money and resources.

Longer Emission Warranty

Protects consumer for worry free operation.

One Star – Low Emission

The one-star label identifies Personal Watercraft, Outboard, Sterndrive and Inboard engines that meet the Air Resource Board's Personal Watercraft and Outboard marine engine 2001 exhaust emission standards. Engines meeting these standards have 75% lower emissions than conventional carbureted two-stroke engines. These engines are equivalent to the U.S. EPA's 2006 standards for marine engines.

Two Stars – Very Low Emission

The two-star label identifies Personal Watercraft, Outboard, Sterndrive and Inboard engines that meet the Air Resources Board's Personal Watercraft and Outboard marine engine 2004 exhaust emission standards. Engines meeting these standards have 20% lower emissions than One Star – Low Emission engines.

Three Stars – Ultra Low Emission

The three-star label identifies engines that meet the Air Resources Board's Personal Watercraft and Outboard marine engine 2008 exhaust emission standards or the Sterndrive and Inboard marine engine 2003 exhaust emission standards. Engines meeting these standards have 65% lower emissions than One Star – Low Emission engines.

Four Stars – Super Ultra Low Emission

The four-star label identifies engines that meet the Air Resources Board's Sterndrive and Inboard marine engine 2009 exhaust emission standards. Personal Watercraft and Outboard marine engines may also comply with these standards. Engines meeting these standards have 90% lower emission than One Star – Low Emission engines.

For more information: Cleaner Watercraft – Get the Facts
1-800-END-SMOG
www.arb.ca.gov

► PRODUCT INFORMATION

YOUR EMISSION CONTROL WARRANTY RIGHTS AND OBLIGATION

The California Air Resources Board and Bombardier Recreational Products (“BRP”) are pleased to explain the emission control system warranty on your 2010 *Evinrude E-TEC* outboard. In California, new outboard engines must be designed, built, and equipped to meet the State’s stringent anti-smog standards. BRP must warrant the emission control system on your outboard for the periods of time listed below provided there has been no abuse, neglect, or improper maintenance of your outboard.

Your emission control system may include parts such as the carburetor or fuel injection system, the ignition system, and catalytic converter. Also included may be hoses, belts, connectors, and other emission-related assemblies.

Where a warrantable condition exists, BRP will repair your outboard at no cost to you including diagnosis, parts, and labor provided that such work is performed by an authorized BRP dealer.

Manufacturer’s Limited Warranty Coverage

This emission limited warranty covers *Evinrude* outboards certified and produced by BRP for sale in California, that are originally sold in California to a California resident, or subsequently warranty-registered to a California resident. The BRP U.S. and Canada limited warranty conditions for *Evinrude* outboards are still applicable to these models with the necessary modifications.

Select emission control parts of your *Evinrude E-TEC* outboard are warranted from the date of purchase by the first retail consumer or the date the product is first put to use, whichever occurs first, for a period of: 4 years, or for 250 hours of use, whichever occurs first.

However, warranty coverage based on the hourly period is only permitted for outboards equipped with the appropriate hour meters or their equivalent. If any emission-related part on your engine is defective under warranty, the part will be repaired or replaced by BRP.

Parts covered are:

1. Electrical System	4. Air Induction System
A. EMM (Engine Management Module)	A. Reed Valves
B. Spark Plugs and Wires	B. Throttle Body Assembly
C. Ignition Coils	C. Intake Manifold
D. Wiring Harness	
	5. Oil System
2. Exhaust System	A. Oil Injector
A. Inner Exhaust Housing	B. Oil Lines, Fittings, and Clamps
B. Adaptor (Exhaust Manifold)	
C. Megaphone (Inner Exhaust)	6. Sensors
	A. Air Temperature Sensor
3. Fuel System	B. Crank Position Sensor
A. Fuel Lift Pump	C. Throttle Position Sensor
B. Fuel Supply Pump	D. Water Temperature Sensor
C. Fuel Injectors	E. Thermostat
D. Vapor Separator	
E. Fuel Lines, Fittings, and Clamps	7. Gaskets
	A. All Emission Component Gaskets

The emission warranty covers damage to other engine components that is caused by the failure of a warranted part.

The BRP Operator’s Guide provided contains written instructions for the proper maintenance and use of your outboard. All emission warranty parts are warranted by BRP for the entire warranty period of the outboard, unless the part is scheduled for replacement as required maintenance in the Operator’s Guide.

Emission warranty parts that are scheduled for replacement, as required maintenance, are warranted by BRP for the period of time before the first scheduled replacement date for that part. Emission warranty parts that are scheduled for regular inspection but not regular replacement are warranted by BRP for the entire warranty period of the outboard. Any emission warranty part repaired or replaced under the terms of this warranty statement is warranted by BRP for the remainder of the warranty period of the original part. All parts replaced under this limited warranty become the property of BRP.

Maintenance receipts and records should be transferred to each subsequent owner of the outboard.

Owner’s Warranty Responsibilities

As the outboard owner, you are responsible for the performance of the required maintenance listed in your Operator’s Guide. BRP recommends that you retain all receipts covering maintenance on your outboard, but BRP cannot deny warranty solely for the lack of receipts or your failure to ensure the performance of all scheduled maintenance.

As the outboard owner, you should however be aware that BRP may deny you warranty coverage if your outboard or a part has failed due to abuse, neglect, improper maintenance, or unapproved modifications.

You are responsible for presenting your outboard to an authorized BRP dealer as soon as a problem exists. The warranty repairs will be completed in a reasonable amount of time, not to exceed 30 days.

For any questions regarding your warranty rights and responsibilities or for the name and location of the nearest authorized BRP dealer, contact BRP US Inc. / Outboard Engines Division, After Sales Support, P.O. Box 597, Sturtevant, WI 53177, 1-847-689-7090 or visit www.evinrude.com.

PRODUCT WARRANTY INFORMATION

BRP LIMITED WARRANTY FOR 2010 EVINRUDE OUTBOARD ENGINES USED IN EUROPEAN UNION MEMBER STATES, TURKEY, AUSTRALIA, NEW ZEALAND AND JAPAN

1. SCOPE OF THE LIMITED WARRANTY

Bombardier Recreational Products Inc. ("BRP") warrants its Evinrude® outboard engines that are sold by authorized Evinrude distributors / dealers and exclusively used, during the warranty period, in European Union member states, Turkey, Australia, New Zealand or Japan ("Product") from defects in material or workmanship for the period and under the conditions described below. For the purpose of this limited warranty.

All Evinrude/Johnson® Genuine Parts and accessories, including but not limited to propellers, gauges, oil tanks, remote controls, wiring and key switches that are installed by an authorized distributor / dealer at the time of sale, whether or not shipped with Product, bear the standard BRP limited warranty for Evinrude/Johnson Genuine Parts and accessories. See your authorized distributor / dealer for a full copy of such limited warranty.

2. WARRANTY COVERAGE PERIOD

This limited warranty will be in effect from the date of purchase by the first retail consumer or the date the Product is first put to use, whichever occurs first, for a period of:

36 CONSECUTIVE MONTHS for private, recreational use; or

12 CONSECUTIVE MONTHS OR 750 HOURS OF OPERATION as determined by Product's Engine Management Module (EMM), whichever occurs first, for commercial use. The Product is used commercially when it is used in connection with any work or employment that generates income, during any part of the warranty period. The Product is also used commercially when, at any point during the warranty period, it is installed on a boat that has commercial tags or is licensed for commercial use.

The repair or replacement of parts or the performance of service to Product under this warranty does not extend the life of this limited warranty beyond its original expiration date.

3. CONDITIONS TO HAVE WARRANTY COVERAGE

This warranty coverage is available only if each of the following conditions has been fulfilled:

- a. Evinrude outboard engines must be purchased as new and unused by its first owner from a BRP distributor / dealer authorized to distribute Evinrude products in the country in which the sale occurred (hereinafter "Distributor / Dealer"),
- b. and then only after the BRP specified pre delivery inspection process has been completed and documented by the purchaser and Distributor / Dealer.
- c. The product must have undergone proper registration of Product by an authorized BRP Distributor / Dealer.
- d. The Evinrude products must be purchased in the country or union of countries in which the purchaser resides.
- e. Routine maintenance outlined in the operator's guide must be timely performed in order to make warranty coverage contingent upon proof of proper maintenance.

BRP will not honour this limited warranty to any private use owner or commercial use owner if the preceding conditions have not been met. Such limitations are necessary in order to allow BRP to protect the safety of its products, its consumers, and the general public.

As outlined in the Operator's Guide, timely routine required maintenance must be performed to maintain warranty coverage. BRP may require proof of proper maintenance prior to authorizing warranty coverage.

4. WHAT TO DO TO OBTAIN WARRANTY COVERAGE

Registered owner ("Owner") must notify within 2 months an authorized Distributor / Dealer of the appearance of a defect. Owner must bring Product, including any defective part therein, to Distributor / Dealer promptly after the appearance of the defect, and in any event, within the warranty period, and must provide Distributor / Dealer with reasonable opportunity to repair the defect. The expenses of transporting Product to and from Distributor / Dealer for warranty service are to be borne by the Owner.

The Owner must also present proof of purchase to the authorized BRP Distributor / Dealer for warranty repairs. Owner is required to sign the repair/work order prior to the start of the repair in order to validate the warranty repair.

► PRODUCT INFORMATION

All parts replaced under this warranty become the property of BRP.

Note that the notification period is subject to the applicable national or local legislation in your country.

5. WHAT BRP WILL DO

BRP's obligations under this warranty are limited to, at its sole discretion, repairing or replacing parts of Product found to be defective in material or workmanship, in the reasonable judgment of BRP. Such repair or replacement of parts will be done without charge for parts and labour, at any authorized Distributor / Dealer, under the conditions described above.

BRP's responsibility is limited to making the required repairs or replacements of parts. No claim of breach of warranty shall be cause for cancellation or rescission of the sale of Product to Owner.

In the event that warranty service is required outside of country of original sale, Owner will bear responsibility for any additional charges due to local practices and conditions, such as, but not limited to, freight, insurance, taxes, license fees, import duties, and any and all other financial charges, including those levied by governments, states, territories and their respective agencies.

BRP reserves the right to improve, modify or change Products from time to time without assuming any obligation to modify Products previously manufactured.

6. EXCLUSIONS -The following are not warranted under any circumstances:

- Replacement of parts due to normal wear and tear;
- Routine maintenance parts and services including but not limited to: maintenance requirements, lower unit oil change, lubrication, linkage adjustments and replacement of fuses, zinc anodes, thermostats, starter motor bushings, trim motor brushes, filters and spark plugs;
- Damage caused by improper installation or lack of maintenance, winterization and/or storage, failure to follow the procedures and recommendations in the Operator's Guide;
- Damage resulting from removal of parts, improper repairs, service, maintenance, or modification, or use of parts or accessories not manufactured or approved by BRP, which in its reasonable judgment, are either incompatible with Product or adversely affect its operation, performance, or durability, or resulting from repairs done by a person that is not an authorized Distributor / Dealer;
- Damage caused by abuse, misuse, abnormal use, neglect, racing, improper operation or operation of the Product in a manner inconsistent with the recommended operation described in the Operator's Guide;
- Damage resulting from accident, submersion, water ingestion, fire, theft, vandalism or any act of God;
- Operation with fuels, oils or lubricants which are not suitable for use with the Product (see the Operator's Guide);
- Damage resulting from rust or corrosion;
- Damage caused from cooling system blockage by foreign material;
- Damage resulting from sand or debris in the water pump; or
- Cosmetic or paint changes due to exposure to the elements.

This warranty will be voided in its entirety and rendered null and void where:

- Product has been altered or modified in such a way so as to adversely affect its operation, performance or durability, or has been altered or modified to change its intended use; or
- Product is or has been used for racing or any other competitive activity, at any point, even by a prior owner.

7. LIMITATIONS OF LIABILITY

ALL WARRANTIES, EXPRESSED OR IMPLIED, INCLUDING WITHOUT LIMITATION ANY WARRANTY OF MERCHANTABILITY OR FITNESS FOR A PARTICULAR PURPOSE ARE LIMITED IN DURATION TO THE LIFE OF THE EXPRESS LIMITED WARRANTY.

ALL INCIDENTAL, CONSEQUENTIAL, DIRECT, INDIRECT OR OTHER DAMAGES OF ANY KIND ARE EXCLUDED FROM COVERAGE UNDER THIS WARRANTY INCLUDING, BUT NOT LIMITED TO: expense for gasoline, expense for transporting Product to and from Distributor / Dealer, removal of Product from a boat and reinstallation, mechanic's travel time, in-and-out of water charges, slip or dock fees, trailering or towing, storage, telephone, cell phone, fax or telegram charges, rental of a like or replacement Product or boat during warranty services or down time, taxi, travel, lodging, loss of or damage to personal property, inconvenience, cost of insurance coverage, loan payments, loss of time, loss of income, revenue or profits, or loss of enjoyment or use of Product.

SOME COUNTRIES, PROVINCES, OR JURISDICTIONS DO NOT ALLOW FOR THE DISCLAIMERS, LIMITATIONS OF INCIDENTAL OR CONSEQUENTIAL DAMAGES, OR OTHER EXCLUSIONS IDENTIFIED ABOVE. AS A RESULT, THEY MAY NOT APPLY TO YOU. THIS WARRANTY GIVES YOU SPECIFIC RIGHTS, AND YOU MAY ALSO HAVE OTHER LEGAL RIGHTS WHICH MAY VARY FROM COUNTRY TO COUNTRY, OR PROVINCE TO PROVINCE.

Neither the Distributor any BRP Distributor / Dealer nor any other person has been authorized to make any affirmation, representation or warranty regarding Product other than those contained in this limited warranty and, if made, shall not be enforceable against BRP.

BRP reserves the right to modify this warranty at any time, being understood that such modification will not alter the warranty conditions applicable to the Products sold while this warranty is in effect.

8. TRANSFER

If the ownership of Product is transferred during the warranty coverage period, this warranty shall also be transferred and be valid for the remaining coverage period provided that the former or new Owner promptly contacts BRP or Distributor / Dealer and gives the name and address of the new Owner.

9. CONSUMER ASSISTANCE

- In the event of a controversy or dispute in connection with this BRP limited warranty, BRP recommends that you first try to resolve the issue at the distributorship / dealership level by discussing the issue with Distributor's / Dealer's service manager or owner;
- You can also locate A BRP office or distributor through our website at www.brp.com.
- If further assistance is required, please contact the Customer Support Services of a BRP affiliate at one of the following numbers, depending on your location:

Australia and New Zealand - Telephone 612-9794-6600, Fax 612-9794-6697
Europe, Turkey, Cyprus - Telephone (41) 21 318 78 00, Fax (41) 21 318 78 61
Japan - Telephone (65) 622-767-55, Fax (65) 622-629-32
Limited Warranty Revision EU February 2009

PRODUCT WARRANTY INFORMATION

BRP LIMITED WARRANTY FOR 2010 EVINRUDE OUTBOARD ENGINES USED IN AFRICA, MIDDLE EAST, LATIN AMERICA, PACIFIC ISLANDS, ASIA, ALBANIA, FORMER YUGOSLAVIAN REPUBLIC OF MACEDONIA, SERBIA AND MONTENEGRO, BOSNIA AND HERZEGOVINA AND THE COMMONWEALTH OF INDEPENDENT STATES

1. SCOPE OF THE LIMITED WARRANTY

Bombardier Recreational Products Inc. ("BRP") warrants its Evinrude® outboard engines ("Product") from defects in material or workmanship for the period and under the conditions described below, when they are sold by authorized Evinrude distributors / dealers and used, at any point during the warranty period, in the following territories:

- Africa,
- Middle East (excluding Turkey),
- Latin America (including but not limited to the Caribbean Islands, Bahamas and Bermuda),
- Pacific Islands (excluding Hawaii),
- Asia (excluding Japan),
- Albania, Former Yugoslavian Republic of Macedonia, Serbia and Montenegro,
- Bosnia and Herzegovina, or
- Commonwealth of Independent States (former Soviet Union) (excluding Lithuania, Latvia and Estonia)

All Evinrude/Johnson® Genuine Parts and accessories, including but not limited to propellers, gauges, oil tanks, remote controls, wiring and key switches that are installed by an authorized distributor / dealer at the time of sale, whether or not shipped with Product, bear the standard BRP limited warranty for Evinrude/Johnson Genuine Parts and accessories. See your authorized distributor / dealer for a full copy of such limited warranty.

2. EXCLUSIONS - ARE NOT WARRANTED:

The following are not warranted under any circumstances:

- Replacement of parts due to normal wear and tear;
- Routine maintenance parts and services including but not limited to: maintenance requirements, lower unit oil change, lubrication, linkage adjustments and replacement of fuses, zinc anodes, thermostats, starter motor bushings, trim motor brushes, filters and spark plugs;
- Damage caused by improper installation or lack of maintenance, winterization and/or storage, failure to follow the procedures and recommendations in the Operator's Guide;
- Damage resulting from removal of parts, improper repairs, service, maintenance, or modification, or use of parts or accessories not manufactured or approved by BRP, which in its reasonable judgment, are either incompatible with Product or adversely affect its operation, performance, or durability, or resulting from repairs done by a person that is not an authorized Distributor / Dealer;
- Damage caused by abuse, misuse, abnormal use, neglect, racing, improper operation or operation of the Product in a manner inconsistent with the recommended operation described in the Operator's Guide;
- Damage resulting from accident, submersion, water ingestion, fire, theft, vandalism or any act of God;
- Operation with fuels, oils or lubricants which are not suitable for use with the Product (see the Operator's Guide);
- Damage resulting from rust or corrosion;
- Damage caused from cooling system blockage by foreign material;
- Damage resulting from sand or debris in the water pump; or
- Cosmetic or paint changes due to exposure to the elements.

This warranty will be voided in its entirety and rendered null and void where:

- Product has been altered or modified in such a way so as to adversely affect its operation, performance or durability, or has been altered or modified to change its intended use; or
- Product is or has been used for racing or any other competitive activity, at any point, even by a prior owner.

3. LIMITATIONS OF LIABILITY

THIS WARRANTY IS EXPRESSLY GIVEN AND ACCEPTED IN LIEU OF ANY AND ALL OTHER WARRANTIES, EXPRESSED OR IMPLIED, INCLUDING WITHOUT LIMITATION ANY WARRANTY OF MERCHANTABILITY OR FITNESS FOR A PARTICULAR PURPOSE. TO THE EXTENT THAT THEY CANNOT BE DISCLAIMED, THE IMPLIED WARRANTIES ARE LIMITED IN DURATION TO THE LIFE OF THE EXPRESS LIMITED WARRANTY.

ALL INCIDENTAL, CONSEQUENTIAL, DIRECT, INDIRECT OR OTHER DAMAGES OF ANY KIND ARE EXCLUDED FROM COVERAGE UNDER THIS WARRANTY INCLUDING, BUT NOT LIMITED TO: expense for gasoline, expense for transporting Product to and from Distributor / Dealer, removal of Product from a boat and reinstallation, mechanic's travel time, in-and-out of water charges, slip or dock fees, trailering or towing, storage, telephone, cell phone, fax or telegram charges, rental of a like or replacement Product or boat during warranty services or down time, taxi, travel, lodging, loss of or damage to personal property, inconvenience, cost of insurance coverage, loan payments, loss of time, loss of income, revenue or profits, or loss of enjoyment or use of Product.

SOME STATES/PROVINCES DO NOT ALLOW FOR THE DISCLAIMERS, LIMITATIONS AND EXCLUSIONS IDENTIFIED ABOVE, AS A RESULT, THEY MAY NOT APPLY TO YOU. THIS WARRANTY GIVES YOU SPECIFIC RIGHTS, AND YOU MAY ALSO HAVE OTHER LEGAL RIGHTS WHICH MAY VARY FROM STATE TO STATE, OR PROVINCE TO PROVINCE.

Neither the Distributor / Dealer, any BRP dealer nor any other person is authorized to make any affirmation, representation or warranty regarding Product other than those contained in this limited warranty and, if made, shall not be enforceable against BRP.

BRP reserves the right to modify this warranty at any time, being understood that such modification will not alter the warranty conditions applicable to the Products sold while this warranty is in effect.

4. WARRANTY COVERAGE PERIOD

This limited warranty will be in effect from the date of purchase by the first retail consumer or the date the Product is first put to use, whichever occurs first, for a period of:

36 CONSECUTIVE MONTHS OR 750 HOURS OF OPERATION as determined by Product's Engine Management Module (EMM), whichever occurs first, for private, recreational use; or

12 CONSECUTIVE MONTHS OR 750 HOURS OF OPERATION as determined by Product's Engine Management Module (EMM), whichever occurs first, for commercial use. The Product is used commercially when it is used in connection with any work or employment that generates income, during any part of the warranty period. The Product is also used commercially when, at any point during the warranty period, it is installed on a boat that has commercial tags or is licensed for commercial use.

The repair or replacement of parts or the performance of service to Product under this warranty does not extend the life of this limited warranty beyond its original expiration date.

5. CONDITIONS TO HAVE WARRANTY COVERAGE

This warranty coverage is available only if each of the following conditions has been fulfilled:

- a. The Evinrude outboard engines must be purchased as new and unused by its first owner from a BRP distributor / dealer authorized to distribute Evinrude products in the country in which the sale occurred ("Distributor /Dealer"),
- b. The BRP specified pre delivery inspection process must be completed and documented by the purchaser and Distributor / Dealer.
- c. The product must have undergone proper registration by an authorized BRP distributor/dealer.
- d. The Evinrude outboard engines must be purchased in the country or union of countries in which the purchaser resides.
- e. Product routine maintenance outlined in the Operator's Guide must be timely performed in order to maintain warranty coverage. BRP reserves the right to make warranty coverage contingent upon proof of proper maintenance.

BRP will not honour this limited warranty to any private owner use owner or commercial use owner if the preceding conditions have not been met. Such limitations are necessary in order to allow BRP to protect the safety of its products, its consumers, and the general public.

6. WHAT TO DO TO OBTAIN WARRANTY COVERAGE

Registered owner ("Owner") must notify a servicing BRP authorized Distributor / Dealer within two (2) days of the appearance of a defect. Owner must bring Product, including any defective part therein, to the authorized brp Distributor / Dealer promptly after the appearance of the defect, and in any event, within the warranty period, and must provide BRP Distributor / Dealer with reasonable opportunity to repair the defect. The expenses of transporting Product to and from Distributor/ Dealer for warranty service are to be borne by the Owner.

The Owner must also present proof of purchase to the authorized BRP Distributor / Dealer for warranty repairs and must sign the repair/work order prior to the start of the repair in order to validate the warranty repair.

All parts replaced under this warranty become the property of BRP.

► **PRODUCT INFORMATION**

7. WHAT BRP WILL DO

BRP's obligations under this warranty are limited to, at its sole discretion, repairing or replacing parts of Product found to be defective in material or workmanship, in the reasonable judgment of BRP. Such repair or replacement of parts will be done without charge for parts and labour, at any authorized Distributor / Dealer. BRP's responsibility is limited to making the required repairs or replacements of parts. No claim of breach of warranty shall be cause for cancellation or rescission of the sale of Product to Owner.

In the event that warranty service is required outside of country of original sale, Owner will bear responsibility for any additional charges due to local practices and conditions, such as, but not limited to, freight, insurance, taxes, license fees, import duties, and any and all other financial charges, including those levied by governments, states, territories and their respective agencies.

BRP reserves the right to improve, modify or change Products from time to time without assuming any obligation to modify Products previously manufactured.

8. TRANSFER

If the ownership of Product is transferred during the warranty coverage period, this warranty shall also be transferred and be valid for the remaining coverage period provided that the former or new Owner promptly contacts BRP or Distributor / Dealer and gives the name and address of the new Owner.

9. CONSUMER ASSISTANCE

- In the event of a controversy or dispute in connection with this BRP limited warranty, BRP recommends that you first try to resolve the issue at the authorized BRP distributorship / dealership level by discussing the issue with Distributor's / Dealer's service manager or owner;
- You can also locate A BRP office or distributor through our website at www.brp.com.
- If further assistance is required, please contact the Customer Support Services of a BRP affiliate at one of the following numbers, depending on your location:

Asia - Telephone (65) 622-767-55, Fax (65) 622-629-32

Africa, Middle East, Albania, Former Yugoslavian Republic of Macedonia, Serbia and Montenegro, Bosnia and Herzegovina and Commonwealth of Independent States (former Soviet Union)
-Telephone (41) 21 318 78 00, Fax (41) 21 318 78 61

Latin America (excluding Brazil) - Telephone 954-846-1442, Fax 954-846-1478

Brazil - Telephone 55 (19) 3246-2100, Fax 55 (19) 3246-3800

Pacific Islands - Telephone 612-9794-6600, Fax 612-9794-6697

Limited Warranty Revision Asia/Latin Am February 2009

READINESS TEST

The Operator's Readiness Test....

1. Did you read this Guide from front cover to rear cover?
2. Are you ready to take responsibility for the safe operation of your boat and outboard?
3. Do you understand all the safety precautions and instructions contained in this Guide?
4. Do you understand that this Guide contains essential information to help prevent personal injury and damage to equipment?
5. Are you ready to follow the recommendations in this Guide and take a boating safety course before you operate your boat and outboard?
6. Do you know who to ask if you have any questions about your boat and outboard?
7. Do you know your local marine traffic laws?
8. Do you understand that human error can be caused by carelessness, fatigue, overload, preoccupation, unfamiliarity of operator with the product, drugs and alcohol, just to name a few?



WARNING

It is impossible for this Guide to cover every hazardous situation you may encounter; however, your understanding of and adherence to essential information contained in this Guide will build good judgment when boating. Always be alert and careful: a good foundation for safety.



FREQUENTLY ASKED QUESTIONS

No dealer-scheduled maintenance for the first three years of normal recreational use? Really?

- Yes! BRP knows you want to spend your time out on the water, not servicing your *Evinrude E-TEC* outboard. There are no valves to adjust, belts to service, chains to replace, or oil to change. We do recommend pre-launch inspections of your outboard at each use and at regular intervals. Salt water applications require minimal additional inspections and lubrication.

What fuel octane is recommended for my Evinrude E-TEC outboard?

- *Evinrude E-TEC* outboards require a minimum octane of 87 (U.S.). Use of higher octane fuels is not harmful, but also not necessary.

What kind of oil does my Evinrude E-TEC outboard require?

- Any TC-W3 oil may be used. The outboard can be programmed by your Dealer to run on *Evinrude/Johnson XD100* oil for lower oil consumption and reduced operating cost. Refer to **Filling the Oil Tank** on page 16; see also **OIL REQUIREMENTS** on page 16.

Do I need to mix oil into my fuel?

- No. *Evinrude E-TEC* outboards do not require any mixing of oil and fuel.

Where should I take my Evinrude E-TEC outboard for service?

- For repairs covered under warranty, you must take your *Evinrude E-TEC* outboard to an authorized dealer. BRP-approved dealers and distributors have received the necessary training to properly service your outboard. Contact BRP for an authorized *Evinrude E-TEC* dealer near you.

Can I order replacement parts and accessories for my Evinrude E-TEC outboard?

- Yes. When replacement parts are required, use *Evinrude/Johnson* Genuine Parts or parts with equivalent characteristics, including type, strength, and material. Using substandard parts could result in injury or product malfunction. Your dealer can order the parts and accessories you desire.

Do I need to complete any paperwork when I move or sell my Evinrude E-TEC outboard?

- Yes. In order to maintain contact with you or the new *Evinrude E-TEC* owner, BRP requests you complete the form outlining **CHANGE OF ADDRESS / CHANGE OF OWNERSHIP** on page 73. This will ensure you or the new owner is made aware of any product announcements and keep the warranty coverage up-to-date.

What do I need to do before storing my Evinrude E-TEC outboard for the winter?

- Winterization is minimal. Refer to **STORAGE** on page 46 for step-by-step instructions to store your *Evinrude E-TEC* outboard for the off-season.



CHANGE OF ADDRESS / CHANGE OF OWNERSHIP

If your address has changed or if there has been a change of ownership, be sure to fill out and mail the form provided on this page.

This notification is necessary for your own safety even after expiration of the original warranty, since BRP will be in a position to contact you if correction to your outboard is required. Outside the U.S. and Canada, this card should be sent to the Bombardier Recreational Products division where the outboard was registered. Please contact your Dealer or Distributor.



Change of Address

Change of Ownership

Model number

Serial Number

Old Address / Previous Owner

Last name

First name M.I.

Address

City

Zip code Country

Phone number

Signature Date

New Address / New Owner

Last name

First name M.I.

Address

City

Zip code Country

Phone number

Signature Date

Dealer Information

Dealer name

Dealer number

Phone number

Contact name

In the U.S. or Canada, mail completed form to: BRP US Inc. / Outboard Engines Division
After Sales Support
P.O Box 597
Sturtevant, WI 53177



CONFIRMATION OF RECEIPT

Your Dealer

Name:	_____

Address:	_____

Upon delivery of your new *Evinrude/Johnson* outboard, complete and sign the form below. Your Dealer will take receipt of the form for their records.

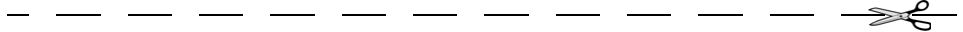

Receipt

Name:	_____

Address:	_____

Owner of Model No:	_____
Serial No:	_____
	(To be completed by customer or selling Dealer)
<p>The Dealer named on this document has instructed me on the operation, maintenance, safety features and warranty policy, all of which I understand and agree to be bound with. I am also satisfied with the predelivery set-up and inspection of my <i>Evinrude/Johnson</i> outboard. I have also received a copy of the Operator's Guide.</p>	
Signature:	_____
Date:	_____